

# **SINGER**

**301-1,-2,-3**

**LIST  
OF  
PARTS**  
FOR FAMILY SHOPS



**SINGER\*\*  
MACHINES**  
Nos. 301-1, 301-2 and 301-3

**THE SINGER MANUFACTURING COMPANY**

**INDEX**

|                                   | Page |
|-----------------------------------|------|
| Accessory .....                   | 13   |
| Attachment Set .....              | 13   |
| Bobbin Winder Parts .....         | 14   |
| Cabinet Trimming Parts .....      | 14   |
| Electrical Equipment .....        | 15   |
| Electrical Fittings .....         | 20   |
| Finger Guard .....                | 22   |
| Foot Controllers .....            | 18   |
| Hemmer Foot .....                 | 22   |
| Light Lamp .....                  | 17   |
| Machine No. 301-1 .....           | 7    |
| Machine No. 301-2 .....           | 12   |
| Machine No. 301-3 .....           | 13   |
| Machine Cradle .....              | 14   |
| Motor Parts .....                 | 15   |
| Needle Threader (Universal) ..... | 22   |
| Numerical List of Parts .....     | 25   |
| Presser Feet .....                | 23   |
| Quilter .....                     | 23   |
| Singer Light .....                | 17   |
| Special Attachments .....         | 23   |

From the library of: Diamond Needle Corp.

## INSTRUCTIONS FOR ORDERING

In ordering from this list, use ONLY the part NUMBER in the FIRST column.

The number stamped on a Sewing Machine Part is in every case the number of the single part only.

Every combination of parts sent out as such has its specific number, which, although not stamped on the parts, must be used when ordering the combination.

Each number always indicates the SAME PART in whatever list it appears, or for whatever machine.

The letters after some of the numbers indicate the style of finish only, as follows:

- A—Hardened, Polished, Nickel Plated and Buffed
- A.A—Buffed and Chromium Plated
- A.B—Hardened, Polished, Buffed and Chromium Plated
- A.C—Brown Baking Enamel Finish
- A.D—Gray Baking Enamel Finish
- A.E—Hardened, Bright Rumbled and Nickel Plated
- A.F—Hardened, Bright Rumbled, Nickel Plated, Bright Rumbled and Chromium Plated
- A.G—Alumilite, Plain
- A.H—Alumilite, Dyed
- A.J—Polished, Nickel Plated and Chromium Plated
- A.K—Hardened, Polished, Nickel Plated and Chromium Plated
- A.L—Heat Treated for Toughness
  - B—Polished, Nickel Plated and Buffed
  - C—Hardened Only
- C.R—Hardened and Merlized
  - D—Polished Only
  - E—Soft, Not Polished
  - F—Hardened and Polished
- F.J—Hardened, Polished and Nickel Plated
  - G—Bright Rumbled and Nickel Plated
  - H—Blued
  - J—Nickel Plated Only
  - K—Hardened and Nickel Plated
  - L—Brass Plated
  - M—Oxidized
  - N—Japanned, Dull
  - P—Japanned, Bright
- P.P—Wrinkle Finish
  - R—Merlized
  - S—Cadmium Plated
  - T—Copper Plated
- T.A—Hardened, Polished, Copper and Nickel Plated and Buffed
- T.B—Copper and Nickel Plated and Polished
- T.J—Copper and Nickel Plated Only
- T.K—Hardened, Copper and Nickel Plated
- T.L—Copper and Brass Plated
- T.M—Copper Plated and Oxidized

## INSTRUCTIONS FOR ORDERING—Continued

- U—Zinc Plated
- V—Silver Plated
- W—Polished and Nickel Plated
- X—Black Oxide, for Iron and Steel
- X.C—Hardened and Black Oxide, for Iron or Steel
- Y—Black Nickel Plated Only
- Z—Chromium Plated
- Z.A—Hardened, Polished, Nickel Plated, Buffed and Chromium Plated
- Z.B—Polished, Nickel Plated, Buffed and Chromium Plated
- Z.C—Hardened and Chromium Plated
- Z.D—Polished and Chromium Plated
- Z.G—Bright Rumbled, Nickel Plated, Bright Rumbled and Chromium Plated
- Z.J—Nickel and Chromium Plated
- Z.T—Copper and Chromium Plated

These letters MUST BE USED when they appear in the list; and AFTER the number as in the list.

In this series:

1 to 1500, 50001 to 51500 and 140001 to 142000 are Screw Numbers

1501 to 1800 and 51501 to 51800 are Nut Numbers

1801 to 2000 and 51801 to 52000 are Roller Numbers

2001 to 50000 and 52001 to 140000 and 142001 to 190000 are Sewing Machine Parts, 190001 and upward are numbers of Electrical Parts.

The figures in the second column refer only to the plates, illustrating the parts, and are NOT TO BE USED in ordering.

Parts marked with an asterisk (\*) are furnished only when repairs are made at factory.

From the plant of Japanned Needle Corp

## LIST OF PARTS COMPLETE

FOR

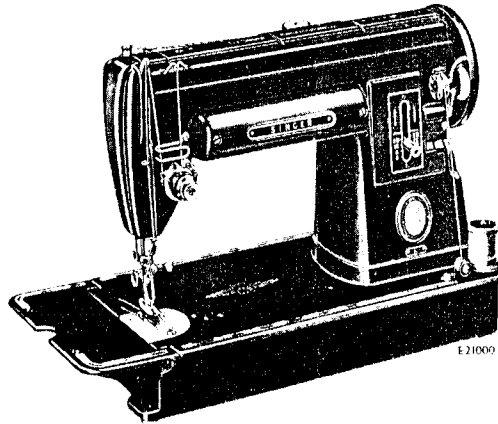

## MACHINE NO. 301-1

PORTABLE FAMILY MACHINE. HORIZONTAL ROTATING  
HOOK. ADJUSTABLE REVERSE FEED. MOTOR DRIVEN

| No.   | Plate | Name  |
|---|-------|---|
| *170001   |       | Arm   |
| *170108   |       | Arm 170001 with 45707, 170005 and 170132  |
| NOTE: Due to the accuracy required for gear alignment, Arm cannot be supplied separately and can only be sent as a unit, Arm and Bed assembled. |       |   |
| 4389  | 25768 | Arm Dowel Pin (2)   |
| 170031  | 25768 | Arm Oil Shield  |
| 140739E   | 25768 | Arm Screw (3)   |
| 170003  | 25768 | Arm Shaft (horizontal) with 1259AL and 140511AL                                     |
| 140558AL  | 25768 | Arm Shaft (horizontal) Bevel Gear, Feed Cam and Feed Lifting Eccentric Set Screw    |
| 170005  | 25768 | Arm Shaft (horizontal) Bushing (2)  |
| 170006  | 25768 | Arm Shaft (horizontal) Collar with 453AL  |
| 453AL   | 25768 | Arm Shaft (horizontal) Collar Set Screw   |
| 170007  | 25768 | Arm Shaft (horizontal) Counterbalance   |
| 140559C   | 25768 | Arm Shaft (horizontal) Counterbalance Screw   |
| 170008  | 25768 | Arm Shaft (upright)   |
| 1259AL  | 25768 | Arm Shaft (upright) Bevel Gear (lower) Set Screw (2)                                |
| 1259AL  | 25768 | Arm Shaft (upright) Bevel Gear (upper) Set Screw (2)                                |
| 45707   | 25768 | Arm Shaft (upright) Bushing (lower)   |
| 170132  | 25768 | Arm Shaft (upright) Bushing (upper)   |
| 170016  | 25769 | Arm Spool Pin (spring)  |
| 8879  | 25769 | Arm Spool Pin Washer (cloth)  |
| 170010  | 25769 | Arm Top Cover   |
| 170011  | 25769 | Arm Top Cover 170010 with 906AL, 170014, 170015 and three 170013                    |
| 170012  | 25769 | Arm Top Cover complete, Nos. 170011, 170056 and two each 140740J, 170057 and 170058 |
| 170013  | 25769 | Arm Top Cover Oil Wick (3)  |
| 141X  | 25769 | Arm Top Cover Screw (2)   |
| 170014  | 25769 | Arm Top Cover Thread Guide (back)   |

| No.   | Plate | Name   |
|---|-------|--|
| 906AL   | 25769 | Arm Top Cover Thread Guide (back) Set Screw                    |
| 170015  | 25769 | Arm Top Cover Thread Guide (front)                             |
| *170023   |       | Bed  |
| *170110   |       | Bed 170023 with 170078, 170079 and two 448AL                   |
| NOTE: Due to the accuracy required for gear alignment, Bed cannot be supplied separately and can only be sent as a unit, Arm and Bed assembled. |       |  |
| 170024  | 25770 | Bed Cover Plate (bottom)                                       |
| 170025  | 25770 | Bed Cover Plate (bottom) 170024 with 170026                    |
| 170026  | 25770 | Bed Cover Plate (bottom) (felt)                                |
| 51361R  | 25770 | Bed Cover Plate (bottom) Screw                                 |
| 51621R  | 25770 | Bed Cover Plate (bottom) Screw Thumb Nut                       |
| 8879  | 25770 | Bed Cover Plate (bottom) Screw Thumb Nut Washer (cloth)        |
| 45780   | 25770 | Bed Cushion (rubber) (4)                                       |
| 140560E   | 25770 | Bed Cushion Screw (4)  |
| 170027  | 25770 | Bed Extension  |
| NOTE: When ordering No. 170027, color required, Beige or Black must be stated.  |       |  |
| 140585ZA  | 25770 | Bed Extension Hinge Screw (back)                               |
| 51108ZA   | 25770 | Bed Extension Hinge Screw (front)                              |
| 170130  | 25770 | Bed Extension Hinge Screw (front) Friction Washer              |
| 170131  | 25770 | Bed Extension Hinge Screw (front) Washer                       |
| 51738ZB   | 25769 | Clamp Stop Motion Clamp Nut                                    |
| 50087ZA   | 25769 | Clamp Stop Motion Clamp Stop Screw                             |
| 170028  | 25769 | Clamp Stop Motion Clamp Washer                                 |
| 170029  | 25772 | Face Plate   |
| 170034  | 25772 | Face Plate 170029 with two 170032                              |
| 170030  | 25772 | Face Plate Catch   |
| 237J  | 25772 | Face Plate Catch Screw   |
| 170032  | 25772 | Face Plate Hinge Pin (2)                                       |
| 170033  | 25772 | Face Plate Thread Guard  |
| 207J  | 25772 | Face Plate Thread Guard Screw                                  |
| 170035  | 25772 | Face Plate complete Nos. 207J, 237J, 170030, 170033 and 170034 |
| NOTE: When ordering No. 170035, color required, Beige or Black must be stated.  |       |  |
| 170036  | 25773 | Feed Bar   |
| 170037  | 25773 | Feed Bar Connecting Link                                       |
| 999C  | 25773 | Feed Bar Connecting Link Hinge Screw                           |
| 45723   | 25773 | Feed Bar Connecting Link Hinge Stud                            |
| 315C  | 25773 | Feed Bar Screw Center (2)                                      |
| 15445   |       | Feed Bar Screw Center 315C with 1519R (2)                      |
| 1519R   | 25773 | Feed Bar Screw Center Nut (2)                                  |
| 170038  | 25773 | Feed Bar Throw-out Lever                                       |
| 170148  | 25773 | Feed Bar Throw-out Lever Clamp Disc (sleeve)                   |
| 170149  | 25773 | Feed Bar Throw-out Lever Screw                                 |
| 170150  |       | Feed Bar Throw-out Lever Screw 170149 with 170151              |
| 1718X   | 25773 | Feed Bar Throw-out Lever Screw Nut                             |
| 170151  | 25773 | Feed Bar Throw-out Lever Screw Thumb Nut                       |
| 170040  | 25773 | Feed Bar Throw-out Lever Spring                                |
| 442E  | 25773 | Feed Bar Throw-out Lever Stop Screw                            |
| 1735E   | 25773 | Feed Bar Throw-out Lever Stop Screw Nut                        |
| 170041  | 25773 | Feed Bar Throw-out Lever Stop Screw Plate                      |
| 1094E   | 25773 | Feed Bar Throw-out Lever Stop Screw Plate Screw                |
| 125349  | 25773 | Feed Bar Throw-out Lever Retaining Ring                        |
| 170044  | 25774 | Feed Dog, 12 teeth (14 teeth to the inch) for 170152           |
| 208AL   | 25774 | Feed Dog Screw (2)   |
| 170045  | 25768 | Feed Forked Connection with 175R and 170119                    |
| 175R  | 25768 | Feed Forked Connection Clamping Screw                          |
| 51353C  | 25768 | Feed Forked Connection Hinge Screw (eccentric)                 |
| 1520R   | 25768 | Feed Forked Connection Hinge Screw Nut                         |
| 170046  | 25768 | Feed Forked Connection Slide Block                             |
| 170119  |       | Feed Forked Connection Slide Block 170046 with 1085E           |

| No.   | Plate | Name   |
|---|-------|--|
| 1085E   | 25768 | Feed Forked Connection Slide Block Screw Stud                  |
| 170047  | 25773 | Feed Lifting Rock Shaft  |
| 170049  | 25773 | Feed Lifting Rock Shaft Center (2)                             |
| 140702AL  | 25773 | Feed Lifting Rock Shaft Center Set Screw (2)                   |
| 170051  | 25768 | Feed Lifting Rock Shaft Connecting Rod with two 896AL          |
| 896AL   | 25768 | Feed Lifting Rock Shaft Connecting Rod Cap Screw (2)           |
| 140576C   | 25768 | Feed Lifting Rock Shaft Connecting Rod Hinge Screw (eccentric) |
| 1520R   | 25768 | Feed Lifting Rock Shaft Connecting Rod Hinge Screw Nut         |
| 170052  | 25768 | Feed Regulator   |
| 140611E   | 25768 | Feed Regulator Hinge Screw                                     |
| 8217  | 25768 | Feed Regulator Hinge Screw Friction Washer                     |
| 170053  | 25768 | Feed Regulator Screw Stud                                      |
| 51739ZB   | 25768 | Feed Regulator Screw Stud Thumb Nut                            |
| 170054  | 25773 | Feed Rock Shaft  |
| 170049  | 25773 | Feed Rock Shaft Center (2)                                     |
| 140702AL  | 25773 | Feed Rock Shaft Center Set Screw (2)                           |
| 170055  | 25773 | Feed Rock Shaft Clearance Hole Cover                           |
| 170017  | 25769 | Hand Wheel   |
| 170018  | 25769 | Hand Wheel 170017 with three 125358                            |
| 170019  | 25769 | Hand Wheel Gear  |
| 170020  | 25769 | Hand Wheel Gear Spring   |
| 125358  | 25769 | Hand Wheel Gear Spring Cushion Pin (3)                         |
| 170021  | 25769 | Hand Wheel Snap Ring   |
| 170022  | 25769 | Hand Wheel complete, Nos. 170018, 170019, 170020 and 170021    |
| NOTE: When ordering No. 170022, color required, Beige or Black must be stated.  |       |  |
| 170056  | 25769 | Machine Handle   |
| NOTE: When ordering No. 170056, color required, Beige or Black, must be stated. |       |  |
| 170057  | 25769 | Machine Handle Hinge Pin (2)                                   |
| 170058  | 25769 | Machine Handle Spring (2)                                      |
| 140740J   | 25769 | Machine Handle Spring Screw (2)                                |
| 170137  | 25775 | Needle Bar (hollow)  |
| 170061  | 25775 | Needle Bar Bushing   |
| 454AL   | 25775 | Needle Bar Bushing Set Screw                                   |
| 170142  | 25775 | Needle Bar Connecting Link                                     |
| 170143  |       | Needle Bar Connecting Link 170142 with 45739                   |
| 45739   | 25775 | Needle Bar Connecting Stud with 51363E                         |
| 51363E  | 25775 | Needle Bar Connecting Stud Clamping Screw                      |
| 140511AL  | 25768 | Needle Bar Crank Position Screw                                |
| 45354   | 25775 | Needle Bar Thread Guard (lower)                                |
| 170133  | 25775 | Needle Bar Thread Guard (upper)                                |
| 665ZB   | 25775 | Needle Bar Thread Guard Screw (2)                              |
| 45877   |       | Needle Clamp Body with 140545ZC                                |
| 45878   | 25775 | Needle Clamp Body 45877 with 51308ZJ                           |
| 170138  | 25775 | Needle Clamp Gib and Thread Guard                              |
| 51308ZJ   | 25775 | Needle Clamp Position Screw                                    |
| 140545ZC  | 25775 | Needle Clamp Thumb Screw                                       |
| 170063  | 25775 | Presser Bar (hollow)   |
| 170064  | 25775 | Presser Bar Bushing  |
| 454AL   | 25775 | Presser Bar Bushing Set Screw                                  |
| 170065  | 25775 | Presser Bar Guide Bracket with 453AL                           |
| 453AL   | 25775 | Presser Bar Guide Bracket Set Screw                            |
| 170066  | 25775 | Presser Bar Lifter   |
| 85E   | 25775 | Presser Bar Lifter Hinge Screw                                 |
| 170067  | 25775 | Presser Bar Spring   |
| 170068  |       | Presser Bar Spring 170067 with 33624                           |
| 170071  | 25774 | Presser Foot (hinged) complete                                 |
| 140240ZB  | 25774 | Presser Foot Thumb Screw                                       |
| 140586ZB  | 25775 | Pressure Regulating Thumb Screw                                |
| 33624   | 25775 | Pressure Regulating Thumb Screw Extension Pin                  |

| No.   | Plate | Name   |
|---|-------|--|
| 170135  | 25776 | Rotating Hook with two 462AL   |
| 170158  | 25776 | Rotating Hook 170135 with 140694F, 170128, 170160, 170166, 200145C and 200614C               |
| 170167  | ..... | Rotating Hook 170135 with 140694F, 170160 and 200614C (for Agents only)                      |
| 170159  | 25776 | Rotating Hook (with Yielding Gib) and Bobbin Case complete, Nos. 45751 and 170158            |
| 45785   | 25777 | Rotating Hook Bobbin   |
| 45751   | 25776 | Rotating Hook Bobbin Case complete, Nos. 45789, 200592C, 200964E, 201016F, 206736 and 210736 |
| 170166  | 25776 | Rotating Hook Bobbin Case Base   |
| 206735  | 25776 | Rotating Hook Bobbin Case Latch  |
| 206736  | 25776 | Rotating Hook Bobbin Case Latch 206735 with 206731 and 206737                                |
| 206731  | 25776 | Rotating Hook Bobbin Case Latch Fulcrum Pin  |
| 206737  | 25776 | Rotating Hook Bobbin Case Latch Lever  |
| 210736  | 25776 | Rotating Hook Bobbin Case Latch Spring   |
| 200964E   | 25776 | Rotating Hook Bobbin Case Latch Stop Screw   |
| 170082  | 25774 | Rotating Hook Bobbin Case Position Plate   |
| 170083  | 25774 | Rotating Hook Bobbin Case Position Plate 170082 with 170084, 170085 and two 51159J           |
| 170084  | 25774 | Rotating Hook Bobbin Case Position Plate Spring (back)                                       |
| 170085  | 25774 | Rotating Hook Bobbin Case Position Plate Spring (front)                                      |
| 51159J  | 25774 | Rotating Hook Bobbin Case Position Plate Spring Screw (2)                                    |
| 233ZJ   | 25774 | Rotating Hook Bobbin Case Position Plate Screw (2)   |
| 45789   | 25776 | Rotating Hook Bobbin Case Tension Spring   |
| 201016F   | 25776 | Rotating Hook Bobbin Case Tension Spring Regulating Screw                                    |
| 200592C   | 25776 | Rotating Hook Bobbin Case Tension Spring Screw   |
| 170095  | 25776 | Rotating Hook Collar and Counterbalance with 447AL   |
| 447AL   | 25776 | Rotating Hook Collar and Counterbalance Set Screw  |
| 170160  | 25776 | Rotating Hook Gib  |
| 200614C   | 25776 | Rotating Hook Gib Hinge Screw  |
| 140694F   | 25776 | Rotating Hook Gib Screw  |
| 170128  | 25776 | Rotating Hook Loop Guard   |
| 200145C   | 25776 | Rotating Hook Loop Guard Screw   |
| 462AL   | 25776 | Rotating Hook Set Screw  |
| 170077  | 25776 | Rotating Hook Shaft  |
| 1259AL  | 25776 | Rotating Hook Shaft Bevel Gear Set Screw   |
| 170078  | 25776 | Rotating Hook Shaft Bushing (back)   |
| 170079  | 25776 | Rotating Hook Shaft Bushing (front)  |
| 448AL   | 25776 | Rotating Hook Shaft Bushing Set Screw (2)  |
| 170081  | 25776 | Rotating Hook Shaft Collar with 465AL  |
| 465AL   | 25776 | Rotating Hook Shaft Collar Set Screw   |
| *170140   | ..... | Set of Mated Gears for Lower Shaft   |
| NOTE: No. 170140 is not supplied to U.S.A. Agencies. Machine must be returned to factory for gear replacements. |       |  |
| *170141   | ..... | Set of Mated Gears for Upper Shaft   |
| NOTE: No. 170141 is not supplied to U.S.A. Agencies. Machine must be returned to factory for gear replacements. |       |  |
| 45863   | 25772 | Slack Thread Regulator and Tension Thread Guide  |
| 335R  | 25772 | Slack Thread Regulator and Tension Thread Guide Screw  |
| 170086  | 25768 | Stitch Indicator Plate   |
| 51384X  | 25768 | Stitch Indicator Plate Screw (2)   |
| 2102  | 25772 | Tension Disc (2)   |
| 125415  | 25772 | Tension Indicator  |
| 45864   | 25772 | Tension Indicator Flange   |
| 45865   | 25772 | Tension Indicator Flange Stop Washer   |
| 51681ZB   | 25772 | Tension Regulating Thumb Nut with 45339  |
| 45339   | 25772 | Tension Regulating Thumb Nut Engaging Pin  |
| 170088  | 25772 | Tension Releasing Lever  |
| 140563C   | 25772 | Tension Releasing Lever Hinge Screw  |
| 12329   | 25772 | Tension Releasing Lever Spring   |

| No.      | Plate | Name  |
|----------|-------|---|
| 45341    | 25772 | Tension Releasing Pin   |
| 45869    | 25772 | Tension Spring  |
| 140167ZJ | 25772 | Tension Stud  |
| 45870    | ..... | Tension Stud 140167ZJ with 51681ZB  |
| 140710AL | 25772 | Tension Stud Set Screw  |
| 170139   | 25772 | Tension (graduated) complete, Nos. 45341, 45864, 45865, 45869, 45870, 45873, 66774, 125415 and two 2102 |
| 170091   | 25775 | Thread Cutter and Holder  |
| 170093   | 25772 | Thread Guard (head of arm)  |
| 330ZA    | 25772 | Thread Guard (head of arm) Screw  |
| 45820    | 25775 | Thread Take-up Crank  |
| 1259AL   | 25768 | Thread Take-up Crank Set Screw  |
| 45821    | 25775 | Thread Take-up Lever  |
| 45822    | ..... | Thread Take-up Lever complete, Nos. 45821, 45824 and 45825  |
| 170163   | 25775 | Thread Take-up Lever 45822 with 1130E, 45820, 140465E, 170143 and 170164                                |
| 140465E  | 25775 | Thread Take-up Lever Cap Screw  |
| 45824    | 25775 | Thread Take-up Lever Hinge Stud   |
| 45825    | 25775 | Thread Take-up Lever Link   |
| 170164   | 25775 | Thread Take-up Lever Link Hinge Stud (eccentric)  |
| 170165   | ..... | Thread Take-up Lever Link Hinge Stud (eccentric) 170164 with 1130E (for Agents only)                    |
| 1130E    | 25775 | Thread Take-up Lever Link Hinge Stud Cap Screw  |
| 448AL    | 25775 | Thread Take-up Lever Link Hinge Stud Set Screw  |
| 66774    | 25772 | Thread Take-up Spring   |
| 45873    | 25772 | Thread Take-up Spring Thread Guard  |
| 170098   | 25774 | Throat Plate  |
| 170152   | 25774 | Throat Plate complete, Nos. 170083, 170098 and two 233ZJ  |
| 691ZA    | 25774 | Throat Plate Screw (2)  |

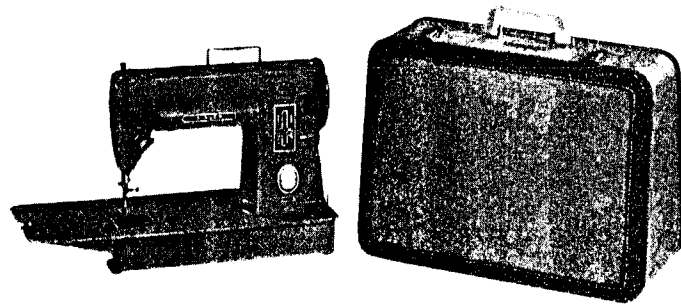

## MACHINE NO. 301-2

FOR USE WITH CARRYING CASE SET NO. 269

This machine is the same as the 301-1 Machine with the following exceptions:

| No.    | Plate | Name                              |
|--------|-------|-----------------------------------|
| 170156 | 25771 | Bed Extension, in place of 170027 |

### ELECTRICAL FITTINGS

|        |       |  |
|--------|-------|--|
| 194583 |       | Foot Controller, for 32 to 55 volts, A.C. or D.C., in place of 194827                                      |
| 194584 | 21398 | Foot Controller, for 95 to 145 volts, A.C. or D.C., in place of 194828                                     |
| 194585 |       | Foot Controller, for 150 to 250 volts, A.C. or D.C., in place of 194829                                    |
| 170157 | 25783 | Three-pin Terminal (female half) Holder and Feed Rock Shaft Clearance Hole Cover Plate, in place of 170129 |
| 196778 | 25783 | Wiring Harness complete, in place of 196222  |

## MACHINE NO. 301-3

FOR USE WITH SCHOOL SEWING AND CUTTING TABLE

SETS NOS. 410, 414, 415 AND 416

This machine is the same as the 301-1 Machine with the following exceptions:

### ELECTRICAL FITTINGS

| No.     | Plate | Name  |
|---------|-------|---|
| 196942  |       | Controller Starting Pitman (2)  |
| 180X    |       | Safety Switch Mounting Bracket Screw (4)  |
| 196912  | 25784 | Safety Switch Electrical Outfit complete for School Tables Nos. 410, 414, 415 and 416, Nos. 196928 and 196929 |
| 140180X |       | Six-pin Terminal with Retaining Plate Screw (4)   |

### ACCESSORY

| No.    | Plate | Name  |
|--------|-------|---|
| 120861 | 25788 | Oil Can, contents 3 fluid oz. (filled with household oil) |

### ATTACHMENT SET

| No.    | Plate | Name   |
|--------|-------|--|
| 8879   | 25777 | Arm Spool Pin Washer (cloth)   |
| 160624 | 25777 | Binder, slotted for various widths of bindings with Pin Tape Guide, for unfolded bias binding 15/16 in. wide (commercial binding No. 6) and folded bias bindings 1/2 in. wide (commercial binding No. 5), 7/16 in. wide (commercial binding No. 4), 3/8 in. wide (commercial binding No. 3), 5/16 in. wide (commercial binding No. 2) and 1/4 inch wide (commercial binding No. 1) |
| 45785  | 25777 | Bobbin (4)   |
| 160625 | 25777 | Edge Stitcher  |
| 160626 | 25777 | Hemmer (adjustable)  |
| 160627 | 25777 | Hemmer (foot) flat bottom, for 5/64 in. hem  |
|        |       | Needles (6)  |
| 160628 | 25777 | Presser Foot for gathering   |
| 25537  | 25777 | Screw Driver (machine)   |
| 120378 | 25777 | Screw Driver (hook tension)  |
| 160629 | 25777 | Ruffler  |
| 160623 | 25777 | Attachment Set, Nos. 8879, 25537, 120378, 160624, 160625, 160626, 160627, 160628, 160629, four 45785 and six Needles   |

**BOBBIN WINDER PARTS**

| No.      | Plate | Name  |
|----------|-------|---|
| 170100   | 25778 | Frame with Pulley and Spindle   |
| 50464X   | 25778 | Frame Hinge Screw   |
| 170107   | 25778 | Frame Spring  |
| 170101   | 25778 | Frame Washer  |
| 15287    | 25778 | Friction Ring (rubber)  |
| 170016   | 25778 | Spool Pin (spring)  |
| 8879     | 25778 | Spool Pin Washer (cloth)  |
| 170109   | 25778 | Stop  |
| 50117R   | 25778 | Stop Screw  |
| 170161   | 25778 | Tension Bracket   |
| 170162   | 25778 | Tension Bracket complete, Nos. 45847, 45915, 45916, 140138ZB and 170161 |
| 205ZB    | 25778 | Tension Bracket Screw   |
| 45915    | 25778 | Tension Disc  |
| 140138ZB | 25778 | Tension Disc Screw  |
| 45916    | 25778 | Tension Disc Screw Washer   |
| 45847    | 25778 | Tension Disc Spring   |

**CABINET TRIMMING PARTS**

| No.     | Plate | Name   |
|---------|-------|--|
| 136409  | 25779 | Machine Cradle Hinge Connection (2)  |
| 2809    | 25779 | Machine Cradle Hinge Connection Pin (2)  |
| 51045AL | 25779 | Machine Cradle Hinge Connection Set Screw (2)  |
| 15263   | 25779 | Machine Cradle Hinge Plate (2)   |
| 136410  | 25779 | Machine Hinge complete, Nos. 2809, 15263, 136409 and wood screws 7/8 in. No. 10 F.H. (2) |
| 136411  | 25779 | Machine Stop (rubber) (2)  |
| 136412  | 25779 | Machine Stop Bracket (left) with two wood screws 5/8 in. No. 7 R.H.B.                    |
| 136413  | 25779 | Machine Stop Bracket (right) with two wood screws 5/8 in. No. 7 R.H.B.                   |

**MACHINE CRADLE**

| No.    | Plate | Name  |
|--------|-------|---|
| 170145 | 25779 | Machine Cradle Felt (bottom)  |
| 964270 | 25779 | Machine Cradle Grommet (2)  |
| 170113 | 25779 | Machine Cradle Latch  |
| 170114 | 25779 | Machine Cradle Latch Shaft  |
| 170116 | 25779 | Machine Cradle Latch Spring   |
| 170117 | ..... | Machine Cradle with 170145 and two 51045AL  |
| 170112 | 25779 | Machine Cradle and Latch complete, Nos. 170113, 170114, 170116, 170117 and two 964270 |

**ELECTRICAL EQUIPMENT**

**CHART FOR PA MOTORS**

| Motor Catalog No. | Volts   | Cycles            |
|-------------------|---------|-------------------|
| PA2-1             | 12      | D.C. only         |
| PA2-3             | 32      | D.C. only         |
| PA2-5             | 50      | 25 to 75 and D.C. |
| PA2-6             | 95-100  | 25 to 75 and D.C. |
| PA2-7             | 100-110 | 25 to 75 and D.C. |
| PA2-8             | 110-120 | 25 to 75 and D.C. |
| PA2-9             | 150-165 | 25 to 75 and D.C. |
| PA2-10            | 190-210 | 25 to 75 and D.C. |
| PA2-11            | 210-230 | 25 to 75 and D.C. |
| PA2-12            | 230-250 | 25 to 75 and D.C. |
| PA2-14            | 120-130 | 25 to 75 and D.C. |
| PA2-15            | 130-145 | 25 to 75 and D.C. |

**MOTOR PARTS**

| No.    | Plate | Name  |
|--------|-------|---|
| 196411 | ..... | Armature with Fan complete for PA2-1 Motor  |
| 196412 | ..... | Armature with Fan complete for PA2-3 Motor  |
| 196413 | ..... | Armature with Fan complete for PA2-5 Motor  |
| 196414 | ..... | Armature with Fan complete for PA2-6 Motor  |
| 196415 | ..... | Armature with Fan complete for PA2-7 Motor  |
| 196252 | 25780 | Armature with Fan complete for PA2-8 Motor  |
| 196416 | ..... | Armature with Fan complete for PA2-9 Motor  |
| 196417 | ..... | Armature with Fan complete for PA2-10 Motor |
| 196418 | ..... | Armature with Fan complete for PA2-11 Motor |
| 196419 | ..... | Armature with Fan complete for PA2-12 Motor |
| 196420 | ..... | Armature with Fan complete for PA2-14 Motor |

From the library of: Dana and Needle Co.



## MOTOR PARTS

| No.     | Plate | Name  |
|---------|-------|---|
| 196421  |       | Armature with Fan complete for PA2-15 Motor                   |
| 195540  | 25780 | Armature Shaft Bearing (commutator end)                       |
| 195541  | 25780 | Armature Shaft Bearing (commutator end) Retainer              |
| 196630  | 25780 | Armature Shaft Bearing (pinion end)                           |
| 829736  | 25780 | Armature Shaft Bearing (pinion end) Retainer                  |
| 517475  | 25780 | Armature Shaft Nut  |
| 196235  | 25780 | Armature Shaft Pinion with 460AL                              |
| 460AL   | 25780 | Armature Shaft Pinion Set Screw                               |
| 196862  | 25780 | Brush (carbon) (2)  |
| 195543  | 25780 | Brush Cover (2)   |
| 140433X | 25780 | Brush Cover Screw (2)   |
| 195547  | 25780 | Brush Holder (2)  |
| 195874  | 25780 | Brush Lead Terminal (2)                                       |
| 196861  | 25780 | Brush Spring (2)  |
| 196617  | 25780 | End Cover (commutator end) with Grease Tube                   |
| 195546  | 25780 | End Cover Disc (felt)   |
| 195545  | 25780 | End Cover Insert (brass) (2)                                  |
| 196433  |       | Field Coil complete for PA2-1 Motor                           |
| 196434  |       | Field Coil complete for PA2-3 Motor                           |
| 196435  |       | Field Coil complete for PA2-5 Motor                           |
| 196436  |       | Field Coil complete for PA2-6 Motor                           |
| 196437  |       | Field Coil complete for PA2-7 Motor                           |
| 196254  | 25780 | Field Coil complete for PA2-8 Motor                           |
| 196438  |       | Field Coil complete for PA2-9 Motor                           |
| 196439  |       | Field Coil complete for PA2-10 Motor                          |
| 196440  |       | Field Coil complete for PA2-11 Motor                          |
| 196441  |       | Field Coil complete for PA2-12 Motor                          |
| 196442  |       | Field Coil complete for PA2-14 Motor                          |
| 196443  |       | Field Coil complete for PA2-15 Motor                          |
| 964514  | 25780 | Field Coil Wedge (2)  |
| 195871  | 25780 | Field Core complete   |
| 196422  |       | Field Core with Coils and Terminals complete for PA2-1 Motor  |
| 196423  |       | Field Core with Coils and Terminals complete for PA2-3 Motor  |
| 196424  |       | Field Core with Coils and Terminals complete for PA2-5 Motor  |
| 196425  |       | Field Core with Coils and Terminals complete for PA2-6 Motor  |
| 196426  |       | Field Core with Coils and Terminals complete for PA2-7 Motor  |
| 196253  |       | Field Core with Coils and Terminals complete for PA2-8 Motor  |
| 196427  |       | Field Core with Coils and Terminals complete for PA2-9 Motor  |
| 196428  |       | Field Core with Coils and Terminals complete for PA2-10 Motor |
| 196429  |       | Field Core with Coils and Terminals complete for PA2-11 Motor |
| 196430  |       | Field Core with Coils and Terminals complete for PA2-12 Motor |
| 196431  |       | Field Core with Coils and Terminals complete for PA2-14 Motor |
| 196432  |       | Field Core with Coils and Terminals complete for PA2-15 Motor |
| 195544  | 25780 | Field Core Wedge  |
| 170118  | 25767 | Motor Hold Down Plate   |
| 690X    | 25767 | Motor Hold Down Plate Screw                                   |
| 196203  | 25780 | Motor Housing (pinion end)                                    |
| 140419X | 25780 | Motor Housing Screw (2)                                       |
| 196234  | 25780 | Motor Housing Terminal Post (2)                               |
| 196236  | 25780 | Motor Housing Terminal Post Insulation                        |
| 190613  | 25780 | Tube filled with Singer Motor Lubricant (packed in carton)    |

## SINGER Light

| No.     | Plate | Name  |
|---------|-------|---|
| 196226  | 25766 | Body (lower half)   |
| 196238  | 25766 | Body (lower half) 196226 with 195143, 196240 and 931728                                       |
| 196227  | 25766 | Body (upper half)   |
| 196237  | 25766 | Body Clamp  |
| 183E    | 25766 | Body Clamp Screw  |
| 195130  | 25766 | Body Snap Ring  |
| 170124  | 25766 | Lamp Shade  |
| 170127  | 25766 | Lamp Shade complete, Nos. 228E, 170124, 170125 and 170126                                     |
| 140579X | 25766 | Lamp Shade Screw (2)  |
| 170125  | 25766 | Lens (blue glass)   |
| 170126  | 25766 | Lens Clamp  |
| 228E    | 25766 | Lens Clamp Screw  |
| 196262  | 25766 | Lead with Terminal Clips and Spring Contacts complete   |
| 964270  | 25766 | Lead Grommet  |
| 196240  | 25766 | Switch Key  |
| 195143  | 25766 | Switch Key Snap Ring  |
| 931728  | 25766 | Switch Key Spring Washer  |
| 195137  |       | Switch Rotating Contact   |
| 195957  | 25766 | Switch Rotating Contact 195137 with 195138 and 195139   |
| 195138  |       | Switch Rotating Contact Cam   |
| 195139  |       | Switch Rotating Contact Cam Insulation  |
| 196221  | 25766 | Singerlight complete (less lamp) Nos. 183E, 195130, 195957, 196227, 196237, 196238 and 196262 |

## LIGHT LAMP

| No.    | Plate | Name       |
|--------|-------|------------|
| 194120 | 25766 | Light Lamp |

NOTE: When ordering No. 194120, state voltage required. We are prepared to furnish the following voltages.

32  
50  
110 to 120  
200 to 220  
230 to 250

## FOOT CONTROLLERS (Bakelite)

(New Style)

### FOR NO. 301-1 MACHINE

| No.     | Plate | Name  |
|---------|-------|---|
| 194827  |       | Controller complete for 32 to 55 volts, A.C. or D.C.<br>Motor, Nos. 194321, 194573, 194825, 196917 and four each 140099X and 194407                   |
| 194828  | 25781 | Controller complete for 95 to 145 volts A.C. or D.C.<br>Motor, Nos. 194321, 194573, 194825, 196918 and four each 140099X and 194407                   |
| 194829  |       | Controller complete for 150 to 250 volts A.C. or D.C.<br>Motor, Nos. 194321, 194573, 194825, 196919 and four each 140099X and 194407                  |
| 196930  | 25781 | Controller Base   |
| 196917  |       | Controller Base 196930 with 196939 and two each 23258, 140103X and 931090   |
| 196918  | 25781 | Controller Base 196930 with 196940 and two each 23258, 140103X and 931090   |
| 196919  |       | Controller Base 196930 with 196941 and two each 23258, 140103X and 931090   |
| 194407  | 25781 | Controller Base Cushion (rubber) (4)  |
| 140099X | 25781 | Controller Base Screw (4)   |
| 194573  | 25781 | Controller Cover  |
| 194321  | 25781 | Controller Foot Pedal   |
| 194825  | 25781 | Controller Lead complete, 60 in. long   |
| 196953  |       | Controller Resistance Unit for 32 to 55 volts, A.C. or D.C.   |
| 196954  | 25781 | Controller Resistance Unit for 95 to 145 volts, A.C. or D.C.  |
| 196955  |       | Controller Resistance Unit for 150 to 250 volts, A.C. or D.C.   |
| 196935  | 25781 | Controller Resistance Unit Linkage  |
| 196937  | 25781 | Controller Resistance Unit Linkage Cross Slide  |
| 1783X   | 25781 | Controller Resistance Unit Linkage Cross Slide Lock Nut   |
| 196939  |       | Controller Resistance Unit with Linkage, Nos. 1783X, 196935, 196937, 196953 and two each 50587J, 51327J, and 193384, for 32 to 55 volts A.C. or D.C.  |
| 196940  |       | Controller Resistance Unit with Linkage, Nos. 1783X, 196935, 196937, 196954 and two each 50587J, 51327J and 193384, for 95 to 145 volts A.C. or D.C.  |
| 196941  |       | Controller Resistance Unit with Linkage, Nos. 1783X, 196935, 196937, 196955 and two each 50587J, 51327J and 193384, for 150 to 250 volts A.C. or D.C. |
| 140103X | 25781 | Controller Resistance Unit Screw (2)  |
| 931090  |       | Controller Resistance Unit Screw Washer (asbestos) (2)  |
| 23258   | 25781 | Controller Resistance Unit Screw Washer (steel) (2)   |
| 193384  | 25781 | Controller Resistance Unit Short Circuiting Contact (2)   |
| 51327J  | 25781 | Controller Resistance Unit Short Circuiting Contact Screw (2)   |
| 50587J  | 25781 | Controller Resistance Unit Terminal Screw (2)   |

## FOOT CONTROLLERS (Bakelite)

(New Style)

### FOR 301-2 MACHINE

| No.     | Plate | Name   |
|---------|-------|--|
| 194583  |       | Controller complete, for 32 to 55 volts, A.C. or D.C. Motor, Nos. 194321, 194573, 194574, 196917 and four each 140099X and 194407                      |
| 194584  | 25787 | Controller complete, for 95 to 145 volts, A.C. or D.C. Motor, Nos. 194321, 194573, 194574, 196918 and four each 140099X and 194407                     |
| 194585  |       | Controller complete, for 150 to 250 volts, A.C. or D.C. Motor, Nos. 194321, 194573, 194574, 196919, and four each 140099X and 194407                   |
| 196930  | 25787 | Controller Base  |
| 196917  |       | Controller Base, 196930 with 196939 and two each 23258, 140103X and 931090   |
| 196918  | 25787 | Controller Base 196930 with 196940 and two each 23258, 140103X and 931090  |
| 196919  |       | Controller Base 196930 with 196941 and two each 23258, 140103X and 931090  |
| 194407  | 25787 | Controller Base Cushion (rubber) (4)   |
| 140099X | 25787 | Controller Base Screw (4)  |
| 194573  | 25787 | Controller Cover   |
| 194321  | 25787 | Controller Foot Pedal  |
| 194575  | 25787 | Controller Lead Cord from Controller to Three-pin Terminal   |
| 194517  | 25787 | Controller Lead Cord from Wall Socket to Three-pin Terminal  |
| 194522  | 25787 | Controller Lead Cord from Wall Socket to Three-pin Terminal, Nos. 194517 and 194518  |
| 194518  | 25787 | Controller Lead Cord Plug  |
| 194574  | 25787 | Controller Lead Cord with Three-pin Terminal complete, Nos. 194521, 194522 and 194575  |
| 196953  |       | Controller Resistance Unit, for 32 to 55 volts A.C. or D.C.  |
| 196954  | 25787 | Controller Resistance Unit, for 95 to 145 volts A.C. or D.C.   |
| 196955  |       | Controller Resistance Unit, for 150 to 250 volts A.C. or D.C.  |
| 196935  | 25787 | Controller Resistance Unit Linkage   |
| 196937  | 25787 | Controller Resistance Unit Linkage Cross Slide   |
| 1783X   | 25787 | Controller Resistance Unit Linkage Cross Slide Lock Nut  |
| 196939  |       | Controller Resistance Unit with Linkage, Nos. 1783X, 196935, 196937, 196953 and two each 50587J, 51327J and 193384, for 32 to 55 volts A.C. or D.C.    |
| 196940  |       | Controller Resistance Unit with Linkage, Nos. 1783X, 196935, 196937, 196954 and two each 50587J, 51327J and 193384, for 95 to 145 volts A.C. or D.C.   |
| 196941  |       | Controller Resistance Unit with Linkage, Nos. 1783X, 196935, 196937, 196955 and two each 50587J, 51327J and 193384, for 150 to 250 volts, A.C. or D.C. |
| 140103X | 25787 | Controller Resistance Unit Screw (2)   |
| 931090  |       | Controller Resistance Unit Screw Washer (asbestos) (2)   |
| 23258   | 25787 | Controller Resistance Unit Screw Washer (steel) (2)  |
| 193384  | 25787 | Controller Resistance Unit Short Circuiting Contact (2)  |
| 51327J  | 25787 | Controller Resistance Unit Short Circuiting Contact Screw (2)  |
| 50587J  | 25787 | Controller Resistance Unit Terminal Screw (2)  |
| 192644  | 25787 | Three-pin Terminal Housing (female half, lower)  |
| 194520  | 25787 | Three-pin Terminal Housing (female half, upper)  |
| 51093X  | 25787 | Three-pin Terminal Housing (female half) Screw (2)   |
| 1768X   | 25787 | Three-pin Terminal Housing (female half) Screw Nut (2)   |
| 192691  | 25787 | Three-pin Terminal Housing (female half) Sleeve (3)  |
| 192692  | 25787 | Three-pin Terminal Housing (female half) Sleeve Nut (3)  |
| 194521  | 25787 | Three-pin Terminal (female half) complete, Nos. 192644, 194520, two each 1768X, 51093X and three each 192691 and 192692                                |

**ELECTRICAL FITTINGS  
FOR  
NO. 301-1 MACHINE**

| No.     | Plate | Name  |
|---------|-------|---|
| 196229  | 25782 | Three-pin Terminal Body (female half, lower)  |
| 196228  | 25782 | Three-pin Terminal Body (female half, upper)  |
| 51093X  | 25782 | Three-pin Terminal Body (female half) Clamping Screw (2)  |
| 1768X   | 25782 | Three-pin Terminal Body (female half) Clamping Screw Nut (2)  |
| 196247  | 25782 | Three-pin Terminal (female half) Lead with Plug and Eyelet  |
| 196291  | 25782 | Three-pin Terminal (female half) less Lead complete, Nos. 196228, 196229 and two each 1768X and 51093X                          |
| 196224  | 25782 | Three-pin Terminal (female half) with Lead complete (from outlet to Machine) Nos 196247 and 196291                              |
| 196231  | 25767 | Three-pin Terminal (male half) with three 140593 (fastened to Machine)  |
| 140593  | 25767 | Three-pin Terminal (male half) Post Screw (3)   |
| 180X    | 25767 | Three-pin Terminal (male half) Screw  |
| 196261  | 25767 | Two-pin Terminal (female half) with two 140593 (fastened to Machine)  |
| 170129  | 25767 | Two-pin Terminal (female half) Holder and Feed Rock Shaft Clearance Hole Cover Plate  |
| 140180X | 25767 | Two-pin Terminal (female half) Holder and Feed Rock Shaft Clearance Hole Cover Plate Screw                                      |
| 51327X  | 25767 | Two-pin Terminal (female half) Screw (2)  |
| 140593  | 25767 | Two-pin Terminal (female half) Terminal Screw (2)   |
| 196230  | 25767 | Two-pin Terminal (male half) Body (lower half)  |
| 196239  | 25767 | Two-pin Terminal (male half) Body (upper half)  |
| 140589X | 25767 | Two-pin Terminal (male half) Body Clamping Screw  |
| 51746X  | 25767 | Two-pin Terminal (male half) Body Clamping Screw Nut  |
| 196260  | 25767 | Two-pin Terminal (male half) Terminal Post (long)   |
| 196242  | 25767 | Two-pin Terminal (male half) Terminal Post (short)  |
| 140590  | 25767 | Two-pin Terminal (male half) Terminal Post Screw (2)  |
| 196272  | 25767 | Two-pin Terminal (male half) complete (Controller Lead End) Nos. 51746X, 140589X, 196230, 196239, 196242, 196260 and two 140590 |
| 196266  | 25767 | Wiring Harness Leads from Three-pin Terminal (male half) to Two-pin Terminal (female half) and to Motor                         |
| 196271  | 25767 | Wiring Harness Lead from Three-pin Terminal (male half) to light  |
| 196222  | 25767 | Wiring Harness complete, Nos. 196231, 196261, 196266 and 196271   |

**ELECTRICAL FITTINGS  
FOR  
NO. 301-2 MACHINE**

| No.    | Plate | Name   |
|--------|-------|--|
| 196269 | 25783 | Lead (black) with Terminal and Insulating Sleeve                                     |
| 196270 | 25783 | Lead (red) with Terminal and Insulating Sleeve                                       |
| 196282 | 25783 | Lead Sleeving  |
| 170157 | 25783 | Two-pin Terminal (female half) Holder and Feed Rock Shaft Clearance Hole Cover Plate |
| 196231 | 25783 | Three-pin Terminal (male half) with three 140593 (fastened to Machine)               |

| No.    | Plate | Name  |
|--------|-------|---|
| 140593 | 25783 | Three-pin Terminal (male half) Post Screw (3)   |
| 196271 | 25783 | Wiring Harness Lead (from Three-pin Terminal to Light)  |
| 196863 |       | Wiring Harness less Three-pin Terminal (male half) (from Three-pin Terminal to Motor, Nos. 196269 and 196270) |
| 196778 | 25783 | Wiring Harness with Three-pin Terminal (male half) complete, Nos. 196231, 196271, 196282 and 196863           |

**ELECTRICAL FITTINGS  
FOR  
NO. 301-3 MACHINE**

SAFETY SWITCH (MERCURY) ELECTRICAL OUTFIT COMPLETE FOR  
SCHOOL TABLES NOS. 410, 414, 415 AND 416

| No.     | Plate | Name  |
|---------|-------|---|
| 196912  |       | Electrical Outfit with Safety Switch complete for School Tables Nos. 410, 414, 415 and 416 Nos. 196901, 196928 and two each 196929 and 197017                                   |
| 196897  | 25784 | Controller with Six-pin Socket and Line Lead complete for 95 to 145 volts, A.C. or D.C. Motor Nos. 194426, 196914, 196975 and two each 50791J and 140102X (2)                   |
| 196931  | 25785 | Controller Base (2)   |
| 196914  | 25785 | Controller Base, 196931 with 23258, 192140, 193384, 193908, 194422, 194479, 194774, 194775, 196931 and two each 50587J, 51327J, 140100X, 140103X, 194421, 194514 and 931090 (2) |
| 50559X  |       | Controller Base Screw (6)   |
| 194603  |       | Controller Base Screw Washer (6)  |
| 194426  | 25785 | Controller Cover (2)  |
| 140102X | 25785 | Controller Cover Screw (4)  |
| 196975  | 25785 | Controller Lead with Six-pin Plug and Line Lead with Clamp and two 50791J   |
| 50587J  |       | Controller Lead with Six-pin Plug and Line Lead Screw (4)   |
| 196907  | 25784 | Controller Lead with Six-pin Plug and Line Lead Retainer (2)  |
| 193908  | 25785 | Controller Lead Clamp (2)   |
| 194479  | 25785 | Controller Lead Clamp Insulation (2)  |
| 192140  | 25785 | Controller Resistance Unit 95 to 145 volts (2)  |
| 194774  | 25785 | Controller Resistance Unit Adjusting Nut (2)  |
| 194775  | 25785 | Controller Resistance Unit Adjusting Nut Lock Spring (2)  |
| 194416  | 25785 | Controller Resistance Unit Bell Crank (2)   |
| 194324  | 25785 | Controller Resistance Unit Bell Crank Connecting Link (2)   |
| 140101C | 25785 | Controller Resistance Unit Bell Crank Connecting Link Hinge Screw (2)   |
| 1607J   |       | Controller Resistance Unit Bell Crank Connecting Link Hinge Screw Nut (2)   |
| 51340C  |       | Controller Resistance Unit Bell Crank Hinge Screw (2)   |
| 1607J   |       | Controller Resistance Unit Bell Crank Hinge Screw Nut (2)   |
| 194421  | 25785 | Controller Resistance Unit Bell Crank Spring (4)  |
| 194402  | 25785 | Controller Resistance Unit Bell Crank Spring Bracket (2)  |
| 194422  |       | Controller Resistance Unit Bell Crank Spring Bracket 194402 with 51340C, 140101C, 194324, 194416, 194773 and two 1607J  |
| 140100X |       | Controller Resistance Unit Bell Crank Spring Bracket Screw (4)  |
| 194514  |       | Controller Resistance Unit Bell Crank Spring Bracket Screw Insulating Disc (4)  |
| 196674  | 25786 | Controller Plug Receptacle (2)  |

**ELECTRICAL FITTINGS**

| No.     | Plate | Name  |
|---------|-------|---|
| 197168  | 25786 | Controller Plug Receptacle Lead (less plug)   |
| 197170  | 25786 | Controller Plug Receptacle Jumper Lead (black)  |
| 196677  | 25786 | Controller Plug Receptacle Jumper Lead (brown)  |
| 196684  | 25786 | Controller Plug Receptacle Jumper Lead (green)  |
| 196683  | ..... | Controller Plug Receptacle Lead 197168 with 196319  |
| 196319  | 25786 | Controller Plug Receptacle Lead Plug with Clamp and two 50764J  |
| 50791J  | 25785 | Controller Plug Receptacle Lead Plug Clamping Screw (4)   |
| 50764J  | 25786 | Controller Plug Receptacle Lead Plug Clamp Clamping Screw (4)   |
| 50637X  | 25786 | Controller Plug Receptacle Screw (4)  |
| 140103X | 25785 | Controller Resistance Unit Screw (4)  |
| 931090  | ..... | Controller Resistance Unit Screw Washer (asbestos) (4)  |
| 23258   | 25785 | Controller Resistance Unit Screw Washer (steel) (2)   |
| 193384  | 25785 | Controller Resistance Unit Short Circuiting Contact (4)   |
| 51327J  | 25785 | Controller Resistance Unit Short Circuiting Contact Screw (4)   |
| 194773  | 25785 | Controller Resistance Unit Yoke (2)   |
| 196942  | ..... | Controller Starting Pitman (2)  |
| 196673  | 25786 | Junction Box  |
| 196682  | 25784 | Junction Box complete, Nos. 196673, 196676, 196677, 196679, 196683, 196684, 197170, two 196674 and four 50637X                        |
| 196679  | 25786 | Junction Box Cover  |
| 196676  | 25786 | Junction Box Strain Relief (two piece)  |
| 196901  | 25784 | Safety Switch (Mercury) Mounting Bracket (2)  |
| 197017  | ..... | Safety Switch (Mercury) Mounting Bracket Gasket (2)   |
| 196892  | 25784 | Wiring Harness with Safety Switch (Mercury) complete (2)  |
| 196929  | ..... | Wiring Outfit complete, Nos. 196892 and 196907 (2)  |
| 196928  | ..... | Wiring Outfit complete for School Tables Nos. 410, 414, 415 and 416 Nos. 196682, two 196897 and four wood Screws 3/4 in. No. 8 R.H.B. |

**FINGER GUARD**

| No.    | Plate | Name         |
|--------|-------|--------------|
| 160851 | ..... | Finger Guard |

**HEMMER FOOT**

| No.    | Plate | Name                               |
|--------|-------|------------------------------------|
| 160753 | 25788 | Hemmer (foot) for Chiffon and Silk |

**NEEDLE THREADER (Universal)**

| No.     | Plate | Name                       |
|---------|-------|----------------------------|
| 121632  | 25788 | Needle Threader            |
| 121631  | 25788 | Needle Threader Hook       |
| 140157J | 25788 | Needle Threader Hook Screw |

**PRESSER FOOT**

**WITH GRADUATED ADJUSTABLE GUIDES**

| No.    | Plate | Name   |
|--------|-------|--|
| 160762 | 25788 | Presser Foot Nos. 337B, 35002, 35206, 36696 and 160763   |
| 35002  | 25788 | Presser Foot Extension   |
| 35003  | 25788 | Presser Foot Graduated Adjustable Guide (long, left)   |
| 35004  | 25788 | Presser Foot Graduated Adjustable Guide (long, right)  |
| 35005  | 25788 | Presser Foot Graduated Adjustable Guide (short, right)   |
| 35006  | 25788 | Presser Foot Graduated Adjustable Guide (short, right, flush)  |
| 160763 | 25788 | Presser Foot Graduated Adjustable Guide Clamp  |
| 35206  | 25788 | Presser Foot Graduated Adjustable Guide Clamp Lever  |
| 337B   | 25788 | Presser Foot Graduated Adjustable Guide Clamp Screw  |
| 36696  | 25788 | Presser Foot Graduated Adjustable Guide Clamp Steady Pin   |
| 160755 | 25788 | Presser Foot with Extension and Graduated Adjustable Guides complete, Nos. 35003, 35004, 35005, 35006 and 160762 |

**PRESSER FEET**

| No.    | Plate | Name  |
|--------|-------|---|
| 160687 | 25788 | Presser Foot (left toe) for stitching on edge and inserting cord  |
| 160688 | 25788 | Presser Foot (right toe) for stitching on edge and inserting cord   |
| 160689 | 25788 | Presser Foot (adjustable, for sewing either on the right or left side of the needle) for cording or slide fastener work |
| 160706 | 25788 | Presser Foot for 160690   |
| 160690 | 25788 | Presser Foot 160706 with 51282J and 121615 for blind stitch braiding, for soutache braid                                |
| 121615 | 25788 | Presser Foot Braid Guide  |
| 51282J | 25788 | NOTE: When ordering No. 121615 or 160690, send sample of braid for which required.                                      |
| 160754 | 25788 | Presser Foot Braid Guide Screw  |
| 160754 | 25788 | Presser Foot for braiding, for art work, for braid 1/16 in. to 3/16 in. wide  |
|        |       | NOTE: When ordering No. 160754, state the size or send a sample of braid for which required.                            |

**QUILTER**

| No.    | Plate | Name    |
|--------|-------|---------|
| 160691 | 25788 | Quilter |

**SPECIAL ATTACHMENTS**

| No.    | Plate | Name                                       |
|--------|-------|--|
| 160986 | ..... | Automatic Zigzagger Attachment complete    |
| 160743 | ..... | Buttonhole Attachment complete             |
| 160823 | ..... | Darning and Embroidery Attachment complete |
| 121634 | ..... | Needle Threader and Seam Ripper complete   |
| 160692 | ..... | Tucker complete                            |

From the library of: **Quilting Needle Corp**

## NUMERICAL LIST OF PARTS

| No.    | Plate | Name  |
|--------|-------|---|
| 85E    | 25775 | Presser Bar Lifter Hinge Screw  |
| 141X   | 25769 | Arm Top Cover Screw   |
| 175R   | 25768 | Feed Forked Connection Clamping Screw for 170045                                      |
| 180X   | ..... | Safety Switch Mounting Bracket Screw for 301-3 Machine                                |
| 180X   | 25767 | Three-pin Terminal (male half) Screw  |
| 183E   | 25766 | Light Body Clamp Screw for 196221   |
| 205ZB  | 25778 | Bobbin Winder Tension Bracket Screw   |
| 207J   | 25772 | Face Plate Thread Guard Screw for 170035  |
| 208AL  | 25774 | Feed Dog Screw  |
| 228E   | 25766 | Light Lens Clamp Screw for 170127   |
| 233ZJ  | 25774 | Rotating Hook Bobbin Case Position Plate Screw for 170152                             |
| 237J   | 25772 | Face Plate Catch Screw for 170035   |
| 315C   | 25773 | Feed Bar Screw Center for 15445   |
| 330ZA  | 25772 | Thread Guard (head of arm) Screw  |
| 335R   | 25772 | Slack Thread Regulator and Tension Thread Guide Screw                                 |
| 337B   | 25788 | Presser Foot Graduated Adjustable Guide Clamp Screw for 160762                        |
| 442E   | 25773 | Feed Bar Throw-out Lever Stop Screw   |
| 447AL  | 25776 | Rotating Hook Collar and Counterbalance Set Screw for 170095                          |
| 448AL  | 25776 | Rotating Hook Shaft Bushing Set Screw for 170110                                      |
| 448AL  | 25775 | Thread Take-up Lever Link Hinge Stud Set Screw  |
| 453AL  | 25768 | Arm Shaft (horizontal) Collar Set Screw for 170006                                    |
| 453AL  | 25775 | Presser Bar Guide Bracket Set Screw for 170065  |
| 454AL  | 25775 | Needle Bar Bushing Set Screw  |
| 454AL  | 25775 | Presser Bar Bushing Set Screw   |
| 460AL  | 25780 | Armature Shaft Pinion Set Screw for 196235  |
| 462AL  | 25776 | Rotating Hook Set Screw for 170135  |
| 465AL  | 25776 | Rotating Hook Shaft Collar Set Screw for 170081                                       |
| 665ZB  | 25775 | Needle Bar Thread Guard Screw   |
| 690X   | 25767 | Motor Hold Down Plate Screw   |
| 691ZA  | 25774 | Throat Plate Screw  |
| 896AL  | 25768 | Feed Lifting Rock Shaft Connecting Rod Cap Screw for 170051                           |
| 906AL  | 25769 | Arm Top Cover Thread Guide (back) Set Screw for 170011                                |
| 999C   | 25773 | Feed Bar Connecting Link Hinge Screw  |
| 1085E  | 25768 | Feed Forked Connection Slide Block Screw Stud for 170119                              |
| 1094E  | 25773 | Feed Bar Throw-out Lever Stop Screw Plate Screw                                       |
| 1130E  | 25775 | Thread Take-up Lever Link Hinge Stud Cap Screw for 170163 and 170165                  |
| 1259AL | 25768 | Arm Shaft (upright) Bevel Gear (lower) Set Screw                                      |
| 1259AL | 25768 | Arm Shaft (upright) Bevel Gear (upper) Set Screw                                      |
| 1259AL | 25776 | Rotating Hook Shaft Bevel Gear Set Screw  |
| 1259AL | 25768 | Thread Take-up Crank Set Screw for 170003   |
| 1519R  | 25773 | Feed Bar Screw Center Nut for 15445   |
| 1520R  | 25768 | Feed Forked Connection Hinge Screw Nut  |
| 1520R  | 25768 | Feed Lifting Rock Shaft Connecting Rod Hinge Screw Nut                                |
| 1607J  | ..... | Controller Resistance Unit Bell Crank Connecting Link Hinge Screw Nut for 194422      |
| 1607J  | ..... | Controller Resistance Unit Bell Crank Hinge Screw Nut for 194422                      |
| 1718X  | 25773 | Feed Bar Throw-out Lever Screw Nut  |
| 1735E  | 25773 | Feed Bar Throw-out Lever Stop Screw Nut   |
| 1768X  | 25782 | Three-pin Terminal Body (female half) Clamping Screw Nut for 196291                   |
| 1768X  | 25787 | Three-pin Terminal Housing (female half) Screw Nut for 194521                         |
| 1783X  | 25781 | Controller Resistance Unit Linkage Cross Slide Lock Nut for 196939, 196940 and 196941 |

| No.     | Plate | Name  |
|---------|-------|---|
| 2102    | 25772 | Tension Disc for 170139   |
| 2809    | 25779 | Machine Cradle Hinge Connection Pin for 136410  |
| 4389    | 25768 | Arm Dowel Pin   |
| 8217    | 25768 | Feed Regulator Hinge Screw Friction Washer  |
| 8879    | 25769 | Arm Spool Pin Washer (cloth)  |
| 8879    | 25777 | Arm Spool Pin Washer (cloth) for 160623   |
| 8879    | 25770 | Bed Cover Plate (bottom) Screw Thumb Nut Washer (cloth)   |
| 8879    | 25778 | Bobbin Winder Spool Pin Washer (cloth)  |
| 12329   | 25772 | Tension Releasing Lever Spring  |
| 15263   | 25779 | Machine Cradle Hinge Plate for 136410   |
| 15287   | 25778 | Bobbin Winder Friction Ring (rubber)  |
| 15445   |       | Feed Bar Screw Center 315C with 1519R   |
| 23258   | 25781 | Controller Resistance Unit Screw Washer (steel) for 196914, 196917, 196918 and 196919                   |
| 25537   | 25777 | Screw Driver (machine) for 160623   |
| 33624   | 25775 | Presser Regulating Thumb Screw Extension Pin for 170068   |
| 35002   | 25788 | Presser Foot Extension for 160762   |
| 35003   | 25788 | Presser Foot Graduated Adjustable Guide (long, left) for 160755   |
| 35004   | 25788 | Presser Foot Graduated Adjustable Guide (long, right) for 160755  |
| 35005   | 25788 | Presser Foot Graduated Adjustable Guide (short, right) for 160755                                       |
| 35006   | 25788 | Presser Foot Graduated Adjustable Guide (short, right, flush) for 160755                                |
| 35206   | 25788 | Presser Foot Graduated Adjustable Guide Clamp Lever for 160762  |
| 36696   | 25788 | Presser Foot Graduated Adjustable Guide Clamp Steady Pin for 160762                                     |
| 45339   | 25772 | Tension Regulating Thumb Nut Engaging Pin for 51681ZB   |
| 45341   | 25772 | Tension Releasing Pin for 170139  |
| 45354   | 25775 | Needle Bar Thread Guard (lower)   |
| 45707   | 25768 | Arm Shaft (upright) Bushing (lower) for 170108  |
| 45723   | 25773 | Feed Bar Connecting Link Hinge Stud   |
| 45739   | 25775 | Needle Bar Connecting Stud with 51363E, for 170143  |
| 45751   | 25776 | Rotating Hook Bobbin Case complete for 170159, Nos. 45789, 200592C, 200964E, 201016F, 206736 and 210736 |
| 45780   | 25770 | Bed Cushion (rubber)  |
| 45785   | 25777 | Rotating Hook Bobbin for 160623   |
| 45789   | 25776 | Rotating Hook Bobbin Case Tension Spring for 45751  |
| 45820   | 25775 | Thread Take-up Crank for 170163   |
| 45821   | 25775 | Thread Take-up Lever for 45822  |
| 45822   |       | Thread Take-up Lever complete for 170163, Nos. 45821, 45824 and 45825                                   |
| 45824   | 25775 | Thread Take-up Lever Hinge Stud for 45822   |
| 45825   | 25775 | Thread Take-up Lever Link for 45822   |
| 45847   | 25778 | Bobbin Winder Tension Disc Spring for 170162  |
| 45863   | 25772 | Slack Thread Regulator and Tension Thread Guide   |
| 45864   | 25772 | Tension Indicator Flange for 170139   |
| 45865   | 25772 | Tension Indicator Flange Stop Washer for 170139   |
| 45869   | 25772 | Tension Spring for 170139   |
| 45870   |       | Tension Stud 140167ZJ with 51681ZB, for 170139  |
| 45873   | 25772 | Thread Take-up Spring Thread Guard for 170139   |
| 45877   |       | Needle Clamp Body with 140545ZC, for 45878  |
| 45878   | 25775 | Needle Clamp Body 45877 with 51308ZJ  |
| 45915   | 25778 | Bobbin Winder Tension Disc for 170162   |
| 45916   | 25778 | Bobbin Winder Tension Disc Screw Washer for 170162  |
| 50087ZA | 25769 | Clamp Stop Motion Clamp Stop Screw  |
| 50117R  | 25778 | Bobbin Winder Stop Screw  |
| 50464X  | 25778 | Bobbin Winder Frame Hinge Screw   |
| 50559X  |       | Controller Base Screw   |

| No.     | Plate | Name  |
|---------|-------|---|
| 50587J  | 25781 | Controller Resistance Unit Terminal Screw for 196939, 196940 and 196941                                 |
| 50587J  |       | Controller Lead with Six-pin Plug and Line Lead Screw for 196914  |
| 50637X  | 25786 | Controller Plug Receptacle Screw for 196682   |
| 50764J  | 25786 | Controller Plug Receptacle Lead Plug Clamp Clamping Screw for 196683                                    |
| 50791J  | 25785 | Controller Plug Receptacle Lead Plug Clamping Screw for 196975  |
| 51045AL | 25779 | Machine Cradle Hinge Connection Set Screw for 170117  |
| 51093X  | 25782 | Three-pin Terminal Body (female half) Clamping Screw for 192691   |
| 51093X  | 25787 | Three-pin Terminal Housing (female half) Screw for 194521   |
| 51108ZA | 25770 | Bed Extension Hinge Screw (front)   |
| 51159J  | 25774 | Rotating Hook Bobbin Case Position Plate Spring Screw for 170083  |
| 51282J  | 25788 | Presser Foot Braid Guide Screw for 160690   |
| 51308ZJ | 25775 | Needle Clamp Position Screw for 45878   |
| 51327J  | 25781 | Controller Resistance Unit Short Circuiting Contact Screw for 192140, 196914, 196939, 196940 and 196941 |
| 51327X  | 25767 | Two-pin Terminal (female half) Screw  |
| 51340C  |       | Controller Resistance Unit Bell Crank Hinge Screw for 194422  |
| 51353C  | 25768 | Feed Forked Connection Hinge Screw (eccentric)  |
| 51361R  | 25770 | Bed Cover Plate (bottom) Screw  |
| 51363E  | 25775 | Needle Bar Connecting Stud Clamping Screw for 45739   |
| 51384X  | 25768 | Stitch Indicator Plate Screw  |
| 51621R  | 25770 | Bed Cover Plate (bottom) Screw Thumb Nut  |
| 51681ZB | 25772 | Tension Regulating Thumb Nut with 45339, for 45870  |
| 51738ZB | 25769 | Clamp Stop Motion Clamp Nut   |
| 51739AB | 25768 | Feed Regulator Screw Stud Thumb Nut   |
| 51746X  | 25767 | Two-pin Terminal (male half) Body Clamping Screw Nut for 196272   |
| 51747S  | 25780 | Armature Shaft Nut  |
| 66774   | 25772 | Thread Take-up Spring for 170139  |
| 120378  | 25777 | Screw Driver (hook tension) for 160623  |
| 120861  | 25788 | Oil Can, contents 3 fluid ozs. (filled with household oil) Accessory                                    |
| 121615  | 25788 | Presser Foot Braid Guide for 160690   |
|         |       | NOTE: When ordering No. 121615 or 160690, send sample of braid for which required.                      |
| 121631  | 25788 | Needle Threader Hook  |
| 121632  | 25788 | Needle Threader (Universal)   |
| 121634  |       | Needle Threader and Seam Ripper complete (Special Attachments)  |
| 125349  | 25773 | Feed Bar Throw-out Lever Retaining Ring   |
| 125358  | 25769 | Hand Wheel Gear Spring Cushion Pin for 170018   |
| 125415  | 25772 | Tension Indicator for 170139  |
| 136409  | 25779 | Machine Cradle Hinge Connection for 136410  |
| 136410  | 25779 | Machine Hinge complete, Nos 2809, 15263, 136409 and wood screws 7/8 in. No. 10 F.H. (Cabinet Trimmings) |
| 136411  | 25779 | Machine Stop (rubber) Cabinet Trimmings   |
| 136412  | 25779 | Machine Stop Bracket (left) with two wood screws 5/8 in. No. 7 R.H.B. (Cabinet Trimmings)               |
| 136413  | 25779 | Machine Stop Bracket (right) with two wood screws 5/8 in. No. 7 R.H.B. (Cabinet Trimmings)              |
| 140099X | 25781 | Controller Base Screw for 194583, 194584, 194585, 194827, 194828 and 194829                             |
| 140100X |       | Controller Resistance Unit Bell Crank Spring Bracket Screw for 196914                                   |
| 140101C | 25785 | Controller Resistance Unit Bell Crank Connecting Link Hinge Screw for 194422                            |

## NUMERICAL LIST OF PARTS

| No.      | Plate | Name   |
|----------|-------|--|
| 140102X  | 25785 | Controller Cover Screw for 196897  |
| 140103X  | 25781 | Controller Resistance Unit Screw for 196914, 196917, 196918 and 196919   |
| 140138ZB | 25778 | Bobbin Winder Tension Disc Screw for 170162  |
| 140157J  | 25788 | Needle Threader Hook Screw   |
| 140167ZJ | 25772 | Tension Stud for 45870   |
| 140180   | 25767 | Two-pin Terminal (female half) Holder and Feed Rock Shaft Clearance Hole Cover Plate Screw   |
| 140180X  | ..... | Six-pin Terminal with Retaining Plate Screw for 301-3 Machine  |
| 140240ZB | 25774 | Presser Foot Thumb Screw   |
| 140419X  | 25780 | Motor Housing Screw  |
| 140433X  | 25780 | Brush Cover Screw  |
| 140465E  | 25775 | Thread Take-up Lever Cap Screw for 170163  |
| 140511AL | 25768 | Needle Bar Crank Position Screw for 170003   |
| 140545ZC | 25775 | Needle Clamp Thumb Screw for 45877   |
| 140558AL | 25768 | Arm Shaft (horizontal) Bevel Gear, Feed Cam and Feed Lifting Eccentric Set Screw   |
| 140559C  | 25768 | Arm Shaft (horizontal) Counterbalance Screw  |
| 140560E  | 25770 | Bed Cushion Screw  |
| 140563C  | 25772 | Tension Releasing Lever Hinge Screw  |
| 140576C  | 25768 | Feed Lifting Rock Shaft Connecting Rod Hinge Screw (eccentric)   |
| 140579X  | 25766 | Light Lamp Shade Screw   |
| 140585ZA | 25770 | Bed Extension Hinge Screw (back)   |
| 140586ZB | 25775 | Pressure Regulating Thumb Screw  |
| 140589X  | 25767 | Two-pin Terminal (male half) Body Clamping Screw for 196272  |
| 140590   | 25767 | Two-pin Terminal (male half) Terminal Post Screw for 196272  |
| 140593   | 25767 | Three-pin Terminal (male half) Post Screw for 196231   |
| 140593   | 25767 | Two-pin Terminal (female half) Terminal Screw for 196261   |
| 140611E  | 25768 | Feed Regulator Hinge Screw   |
| 140694F  | 25776 | Rotating Hook Gib Screw for 170158 and 170167  |
| 140702AL | 25773 | Feed Lifting Rock Shaft Center Set Screw   |
| 140702AL | 25773 | Feed Rock Shaft Center Set Screw   |
| 140710AL | 25772 | Tension Stud Set Screw   |
| 140739E  | 25768 | Arm Screw  |
| 140740J  | 25769 | Machine Handle Spring Screw for 170012   |
| 160623   | 25777 | Attachment Set Nos. 8879, 25537, 120378, 160624, 160625, 160626, 160627, 160628, 160629, four 45785 and six needles  |
| 160624   | 25777 | Binder, slotted for various widths of bindings with Pin Tape Guide, for unfolded bias binding 15/16 in. wide (commercial binding No. 6) and folded bias bindings 1/2 in. wide (commercial binding No. 5), 7/16 in. wide (commercial binding No. 4), 3/8 in. wide (commercial binding No. 3), 5/16 in. wide (commercial binding No. 2), and 1/4 in. wide (commercial binding No. 1), for 160623 |
| 160625   | 25777 | Edge Stitcher for 160623   |
| 160626   | 25777 | Hemmer (adjustable) for 160623   |
| 160627   | 25777 | Hemmer (foot) flat bottom, for 5/64 in. hem, for 160623  |
| 160628   | 25777 | Presser Foot for gathering for 160623  |
| 160629   | 25777 | Ruffler for 160623   |
| 160687   | 25788 | Presser Foot (left toe) for stitching on edge and inserting cord   |
| 160688   | 25788 | Presser Foot (right toe) for stitching on edge and inserting cord  |
| 160689   | 25788 | Presser Foot (adjustable, for sewing either on the right or left side of the needle) for cording or slide fastener work  |
| 160690   | 25788 | Presser Foot 160706 with 51282J and 121615 for blind stitch braiding, for soutache braid   |

## NUMERICAL LIST OF PARTS

| No.  | Plate | Name   |
|--|-------|--|
| 160691   | 25788 | Quilter complete   |
| 160692   | ..... | Tucker complete (Special Attachments)  |
| 160706   | 25788 | Presser Foot for 160690  |
| 160743   | ..... | Buttonhole Attachment complete (Special Attachments)   |
| 160753   | 25788 | Hemmer (foot) for Chiffon and Silk   |
| 160754   | 25788 | Presser Foot for braiding, for art work, for braid 1/16 in. to 3/16 in wide                                      |
| NOTE: When ordering No. 160754, state the size or send a sample of braid for which required. |       |  |
| 160755   | 25788 | Presser Foot with Extension and Graduated Adjustable Guides complete, Nos. 35003, 35004, 35005, 35006 and 160762 |
| 160762   | 25788 | Presser Foot for 160755, Nos. 337B, 35002, 35206, 36696 and 160763   |
| 160763   | 25788 | Presser Foot Graduated Adjustable Guide Clamp for 160762   |
| 160823   | ..... | Darning and Embroidery Attachment complete (Special Attachments)   |
| 160851   | ..... | Finger Guard   |
| 160986   | ..... | Automatic Zigzagger Attachment complete (Special Attachments)  |
| *170001  | ..... | Arm for 170108   |
| 170003   | 25768 | Arm Shaft (horizontal) with 1259AL and 140511AL  |
| 170005   | 25768 | Arm Shaft (horizontal) Bushing for 170108  |
| 170006   | 25768 | Arm Shaft (horizontal) Collar with 453AL   |
| 170007   | 25768 | Arm Shaft (horizontal) Counterbalance  |
| 170008   | 25768 | Arm Shaft (upright)  |
| 170010   | 25769 | Arm Top Cover for 170011   |
| 170011   | 25769 | Arm Top Cover 170010 with 906AL, 170014, 170015 and three 170013, for 170012                                     |
| 170012   | 25769 | Arm Top Cover complete, Nos. 170011, 170016 and two each 140740J, 170057 and 170058                              |
| 170013   | 25769 | Arm Top Cover Oil Wick for 170011  |
| 170014   | 25769 | Arm Top Cover Thread Guide (back) for 170011   |
| 170015   | 25769 | Arm Top Cover Thread Guide (front) for 170011  |
| 170016   | 25769 | Arm Spool Pin (spring)   |
| 170016   | 25778 | Bobbin Winder Spool Pin (spring)   |
| 170017   | 25769 | Hand Wheel for 170018  |
| 170018   | 25769 | Hand Wheel 170017 with three 125358, for 170022  |
| 170019   | 25769 | Hand Wheel Gear for 170022   |
| 170020   | 25769 | Hand Wheel Gear Spring for 170022  |
| 170021   | 25769 | Hand Wheel Snap Ring for 170022  |
| 170022   | 25769 | Hand Wheel complete, Nos. 170018, 170019, 170020 and 170021  |
| NOTE: When ordering No. 170022, color required, Beige or Black, must be stated.              |       |  |
| *170023  | ..... | Bed for 170110   |
| 170024   | 25770 | Bed Cover Plate (bottom) for 170025  |
| 170025   | 25770 | Bed Cover Plate (bottom) 170024 with 170026  |
| 170026   | 25770 | Bed Cover Plate (bottom) felt, for 170025  |
| 170027   | 25770 | Bed Extension for 301-1 and 301-3 Machines   |
| NOTE: When ordering No. 170027, color required, Beige or Black, must be stated.              |       |  |
| 170028   | 25769 | Clamp Stop Motion Clamp Washer   |
| 170029   | 25772 | Face Plate for 170034  |
| 170030   | 25772 | Face Plate Catch for 170035  |
| 170031   | 25768 | Arm Oil Shield   |
| 170032   | 25772 | Face Plate Hinge Pin for 170034  |
| 170033   | 25772 | Face Plate Thread Guard for 170035   |
| 170034   | 25772 | Face Plate 170029 with two 170032, for 170035  |
| 170035   | 25772 | Face Plate complete, Nos. 207J, 237J, 170030, 170033 and 170034  |
| 170036   | 25773 | Feed Bar   |
| 170037   | 25773 | Feed Bar Connecting Link   |

| No.   | Plate | Name   |
|---|-------|--|
| 170038  | 25773 | Feed Bar Throw-out Lever   |
| 170040  | 25773 | Feed Bar Throw-out Lever Spring  |
| 170041  | 25773 | Feed Bar Throw-out Lever Stop Screw Plate  |
| 170044  | 25774 | Feed Dog, 12 teeth (14 teeth to the inch) for 170152   |
| 170045  | 25768 | Feed Forked Connection with 175R and 170119  |
| 170046  | 25768 | Feed Forked Connection Slide Block for 170119  |
| 170047  | 25773 | Feed Lifting Rock Shaft  |
| 170049  | 25773 | Feed Lifting Rock Shaft Center   |
| 170049  | 25773 | Feed Rock Shaft Center   |
| 170051  | 25768 | Feed Lifting Shaft Connecting Rod with two 896AL   |
| 170052  | 25768 | Feed Regulator   |
| 170053  | 25768 | Feed Regulator Screw Stud  |
| 170054  | 25773 | Feed Rock Shaft  |
| 170055  | 25773 | Feed Rock Shaft Clearance Hole Cover for 301-1 Machine   |
| 170056  | 25769 | Machine Handle for 170012  |
| NOTE: When ordering No. 170056, color required, Beige or Black, must be stated.   |       |  |
| 170057  | 25769 | Machine Handle Hinge Pin for 170012  |
| 170058  | 25769 | Machine Handle Spring for 170012   |
| 170061  | 25775 | Needle Bar Bushing   |
| 170063  | 25775 | Presser Bar (hollow)   |
| 170064  | 25775 | Presser Bar Bushing  |
| 170065  | 25775 | Presser Bar Guide Bracket with 453AL   |
| 170066  | 25775 | Presser Bar Lifter   |
| 170067  | 25775 | Presser Bar Spring for 170068  |
| 170068  | 25775 | Presser Bar Spring 170067 with 33624   |
| 170071  | 25774 | Presser Foot (hinged) complete   |
| 170077  | 25776 | Rotating Hook Shaft  |
| 170078  | 25776 | Rotating Hook Shaft Bushing (back) for 170110  |
| 170079  | 25776 | Rotating Hook Shaft Bushing (front) for 170110   |
| 170081  | 25776 | Rotating Hook Shaft Collar with 465AL  |
| 170082  | 25774 | Rotating Hook Bobbin Case Position Plate for 170083  |
| 170083  | 25774 | Rotating Hook Bobbin Case Position Plate 170082 with 170084, 170085 and two 51159J, for 170152                     |
| 170084  | 25774 | Rotating Hook Bobbin Case Position Plate Spring (back) for 170083  |
| 170085  | 25774 | Rotating Hook Bobbin Case Position Plate Spring (front) for 170083   |
| 170086  | 25768 | Stitch Indicator Plate   |
| 170088  | 25772 | Tension Releasing Lever  |
| 170091  | 25775 | Thread Cutter and Holder   |
| 170093  | 25772 | Thread Guard (head of arm)   |
| 170095  | 25776 | Rotating Hook Collar and Counterbalance with 447AL   |
| 170098  | 25774 | Throat Plate for 170152  |
| 170100  | 25778 | Bobbin Winder Frame with Pulley and Spindle  |
| 170101  | 25778 | Bobbin Winder Frame Washer   |
| 170107  | 25778 | Bobbin Winder Frame Spring   |
| *170108   | 25778 | Arm 170001 with 45707, 170005 and 170132   |
| NOTE: Due to the accuracy required for gear alignment, Arm cannot be supplied separately and can only be sent as a unit, Arm and Bed assembled. |       |  |
| 170109  | 25778 | Bobbin Winder Stop   |
| *170110   | 25778 | Bed 170023 with 170078, 170079 and two 448AL   |
| NOTE: Due to the accuracy required for gear alignment, Bed cannot be supplied separately and can only be sent as a unit, Arm and Bed assembled. |       |  |
| 170112  | 25779 | Machine Cradle and Latch complete for 301-1 and 301-3 Machines, Nos. 170113, 170114, 170116, 170117 and two 964270 |
| 170113  | 25779 | Machine Cradle Latch for 170112  |
| 170114  | 25779 | Machine Cradle Latch Shaft for 170112  |
| 170116  | 25779 | Machine Cradle Latch Spring for 170112   |

| No.   | Plate | Name  |
|---|-------|---|
| 170117  | 25776 | Machine Cradle with 170145 and two 51045AL, for 170112  |
| 170118  | 25767 | Motor Hold Down Plate   |
| 170119  | 25766 | Feed Forked Connection Slide Block 170046 with 1085E, for 170045  |
| 170124  | 25766 | Light Lamp Shade for 170127   |
| 170125  | 25766 | Light Lens (blue glass) for 170127  |
| 170126  | 25766 | Light Lens Clamp for 170127   |
| 170127  | 25766 | Light Lamp Shade complete, Nos. 228E, 170124, 170125 and 170126   |
| 170128  | 25776 | Rotating Hook Loop Guard for 170158   |
| 170129  | 25767 | Two-pin Terminal (female half) Holder and Feed Rock Shaft Clearance Hole Cover Plate                    |
| 170130  | 25770 | Bed Extension Hinge Screw (front) Friction Washer   |
| 170131  | 25770 | Bed Extension Hinge Screw (front) Washer  |
| 170132  | 25768 | Arm Shaft (upright) Bushing (upper) for 170108  |
| 170133  | 25775 | Needle Bar Thread Guard (upper)   |
| 170135  | 25776 | Rotating Hook with two 462AL, for 170158 and 170167   |
| 170137  | 25775 | Needle Bar (hollow)   |
| 170138  | 25775 | Needle Clamp Gib and Thread Guard   |
| 170139  | 25772 | Tension (graduated) complete, Nos. 45341, 45864, 45865, 45869, 45870, 45873, 66774, 125415 and two 2102 |
| *170140   | 25772 | Set of Mated Gears for Lower Shaft  |
| NOTE: No. 170140 is not supplied to U.S.A. Agencies. Machine must be returned to factory for gear replacements. |       |   |
| *170141   | 25772 | Set of Mated Gears for Upper Shaft  |
| NOTE: No. 170141 is not supplied to U.S.A. Agencies. Machine must be returned to factory for gear replacements. |       |   |
| 170142  | 25775 | Needle Bar Connecting Link for 170143   |
| 170143  | 25775 | Needle Bar Connecting Link 170142 with 45739, for 170163  |
| 170145  | 25779 | Machine Cradle Felt (bottom) for 170117   |
| 170148  | 25773 | Feed Bar Throw-out Lever Clamp Disc (sleeve)  |
| 170149  | 25773 | Feed Bar Throw-out Lever Screw for 170150   |
| 170150  | 25773 | Feed Bar Throw-out Lever Screw 170149 with 170151   |
| 170151  | 25773 | Feed Bar Throw-out Lever Screw Thumb Nut for 170150   |
| 170152  | 25774 | Throat Plate complete for 170044, Nos. 170083, 170098 and two 233ZJ                                     |
| 170156  | 25771 | Bed Extension for 301-2 Machine   |
| 170157  | 25783 | Two-pin Terminal (female half) Holder and Feed Rock Shaft Clearance Hole Cover Plate for 301-2 Machine  |
| 170158  | 25776 | Rotating Hook 170135 with 140694F, 170128, 170160, 170166, 200145C and 200614C, for 170159              |
| 170159  | 25776 | Rotating Hook (with Yielding Gib) and Bobbin Case complete, Nos. 45751 and 170158                       |
| 170160  | 25776 | Rotating Hook Gib for 170158 and 170167   |
| 170161  | 25778 | Bobbin Winder Tension Bracket for 170162  |
| 170162  | 25778 | Bobbin Winder Tension Bracket complete, Nos. 45847, 45915, 45916, 1401382B and 170161                   |
| 170163  | 25775 | Thread Take-up Lever 45822 with 1130E, 45820, 140465E, 170143 and 170164                                |
| 170164  | 25775 | Thread Take-up Lever Link Hinge Stud (eccentric) for 170163 and 170165                                  |
| 170165  | 25775 | Thread Take-up Lever Link Hinge Stud (eccentric) 170164 with 1130E (for Agents only)                    |
| 170166  | 25776 | Rotating Hook Bobbin Case Base for 170158   |
| 170167  | 25776 | Rotating Hook 170135 with 140694F, 170160 and 200614C (for Agents only)                                 |
| 190613  | 25780 | Tube filled with Singer Motor Lubricant (packed in carton)  |
| 192140  | 25785 | Controller Resistance Unit for 95 to 145 volts, for 196914  |
| 192644  | 25787 | Three-pin Terminal Housing (female half, lower) for 194521  |



## NUMERICAL LIST OF PARTS

| No.    | Plate | Name   |
|--------|-------|--|
| 192691 | 25787 | Three-pin Terminal Housing (female half) Sleeve for 194521   |
| 192692 | 25787 | Three-pin Terminal Housing (female half) Sleeve Nut for 194521   |
| 193384 | 25781 | Controller Resistance Unit Short Circuiting Contact for 196914, 196939, 196940 and 196941  |
| 193908 | 25785 | Controller Lead Clamp for 196914   |
| 194120 | 25766 | Light Lamp   |
|        |       | NOTE: When ordering No. 194120, state voltage required.  |
| 194321 | 25781 | Controller Foot Pedal for 194583, 194584, 194585, 194827, 194828 and 194829  |
| 194324 | 25785 | Controller Resistance Unit Bell Crank Connecting Link for 194422   |
| 194402 | 25785 | Controller Resistance Unit Bell Crank Spring Bracket for 194422  |
| 194407 | 25781 | Controller Base Cushion (rubber) for 194583, 194584, 194585, 194827, 194828 and 194829   |
| 194416 | 25785 | Controller Resistance Unit Bell Crank for 194422   |
| 194421 | 25785 | Controller Resistance Unit Bell Crank Spring for 196914  |
| 194422 |       | Controller Resistance Unit Bell Crank Spring Bracket 194402 with 51340C, 140101C, 194324, 194416, 194773 and two 1607J, for 196914                         |
| 194426 | 25785 | Controller Cover for 196897  |
| 194479 | 25785 | Controller Lead Clamp Insulation for 196914  |
| 194514 |       | Controller Resistance Unit Bell Crank Spring Bracket Screw Insulating Disc for 196914  |
| 194517 | 25787 | Controller Lead Cord from Wall Socket to Three-pin Terminal for 194522   |
| 194518 | 25787 | Controller Lead Cord Plug for 194522   |
| 194520 | 25787 | Three-pin Terminal Housing (female half, upper) for 194521   |
| 194521 | 25787 | Three-pin Terminal (female half) complete for 194574, Nos. 192644, 194520, two each 1768X, 51093X and three each 192691 and 192692                         |
| 194522 | 25787 | Controller Lead Cord from Wall Socket to Three-Pin Terminal, Nos. 194517 and 194518, for 194574  |
| 194573 | 25781 | Controller Cover for 194583, 194584, 194585, 194827, 194828 and 194829   |
| 194574 | 25787 | Controller Lead Cord with Three-pin Terminal complete for 194583, 194584, 194585, Nos. 194521, 194522 and 194575   |
| 194575 | 25787 | Controller Lead Cord from Controller to Three-pin Terminal for 194574  |
| 194583 |       | Foot Controller complete, for 32 to 55 volts, A.C. or D.C. Motor for 301-2 Machine, Nos. 194321, 194573, 194574, 196917 and four each 140099X and 194407   |
| 194584 | 25787 | Foot Controller complete, for 95 to 145 volts, A.C. or D.C. Motor for 301-2 Machine, Nos. 194321, 194573, 194574, 196918 and four each 140099X and 194407  |
| 194585 |       | Foot Controller complete, for 150 to 250 volts, A.C. or D.C. Motor for 301-2 Machine, Nos. 194321, 194573, 194574, 196919 and four each 140099X and 194407 |
| 194603 |       | Controller Base Screw Washer   |
| 194773 | 25785 | Controller Resistance Unit Yoke for 194422   |
| 194774 | 25785 | Controller Resistance Unit Adjusting Nut for 196914  |
| 194775 | 25785 | Controller Resistance Unit Adjusting Nut Lock Spring for 196914  |
| 194825 | 25781 | Controller Lead complete, 60 in. long for 194827, 194828 and 194829  |
| 194827 |       | Controller complete, for 32 to 55 volts, A.C. or D.C. Motor for 301-1 Machine, Nos. 194321, 194573, 194825, 196917 and four each 140099X and 194407        |

## NUMERICAL LIST OF PARTS

| No.    | Plate | Name  |
|--------|-------|---|
| 194828 | 25781 | Controller complete, for 95 to 145 volts, A.C. or D.C. Motor for 301-1 Machine, Nos. 194321, 194573, 194825, 196918 and four each 140099X and 194407  |
| 194829 |       | Controller complete, for 150 to 250 volts, A.C. or D.C. Motor for 301-1 Machine, Nos. 194321, 194573, 194825, 196919 and four each 140099X and 194407 |
| 195130 | 25766 | Light Body Snap Ring for 196221   |
| 195137 |       | Light Switch Rotating Contact for 195957  |
| 195138 |       | Light Switch Rotating Contact Cam for 195957  |
| 195139 |       | Light Switch Rotating Contact Cam Insulation for 195957   |
| 195143 | 25766 | Light Switch Key Snap Ring for 196238   |
| 195540 | 25780 | Armature Shaft Bearing (commutator end)   |
| 195541 | 25780 | Armature Shaft Bearing (commutator end) Retainer  |
| 195543 | 25780 | Brush Cover   |
| 195544 | 25780 | Field Core Wedge  |
| 195545 | 25780 | End Cover Insert (brass)  |
| 195546 | 25780 | End Cover Disc (felt)   |
| 195547 | 25780 | Brush Holder  |
| 195871 | 25780 | Field Core complete   |
| 195874 | 25780 | Brush Lead Terminal   |
| 195957 | 25766 | Light Switch Rotating Contact 195137 with 195138 and 195139, for 196221   |
| 196203 | 25780 | Motor Housing (pinion end)  |
| 196221 | 25766 | Light complete (less lamp) Nos. 183E, 195130, 195957, 196227, 196237, 196238 and 196262   |
| 196222 | 25767 | Wiring Harness complete for 301-1 Machine, Nos. 196231, 196261, 196266 and 196271   |
| 196224 | 25782 | Three-pin Terminal (female half) with Lead complete (from outlet to Machine) for 301-1 Machine, Nos. 196247 and 196291                                |
| 196226 | 25766 | Light Body (lower half) for 196238  |
| 196227 | 25766 | Light Body (upper half) for 196221  |
| 196228 | 25782 | Three-pin Terminal Body (female half, upper) for 196291   |
| 196229 | 25782 | Three-pin Terminal Body (female half, lower) for 196291   |
| 196230 | 25767 | Two-pin Terminal (male half) Body (lower half) for 196272   |
| 196231 | 25767 | Three-pin Terminal (male half) with three 140593 (fastened to Machine) for 196222 and 196778  |
| 196234 | 25780 | Motor Housing Terminal Post   |
| 196235 | 25780 | Armature Shaft Pinion with 460AL  |
| 196236 | 25780 | Motor Housing Terminal Post Insulation  |
| 196237 | 25766 | Light Body Clamp for 196221   |
| 196238 | 25766 | Light Body (lower half) 196226 with 195143, 196240 and 931728, for 196221   |
| 196239 | 25767 | Two-pin Terminal (male half) Body (upper half) for 196272   |
| 196240 | 25766 | Light Switch Key for 196238   |
| 196242 | 25767 | Two-pin Terminal (male half) Terminal Post (short) for 196272   |
| 196247 | 25782 | Three-pin Terminal (female half) Lead with Plug and Eyelet for 196224   |
| 196252 | 25780 | Armature with Fan complete for PA2-8 Motor  |
| 196253 |       | Field Core with Coils and Terminals complete for PA2-8 Motor  |
| 196254 | 25780 | Field Core complete for PA2-8 Motor   |
| 196260 | 25767 | Two-pin Terminal (male half) Terminal Post (long) for 196272  |
| 196261 | 25767 | Two-pin Terminal (female half) with two 140593 (fastened to Machine) for 196222   |
| 196262 | 25766 | Light Lead with Terminal Clips and Spring Contacts complete for 196221  |
| 196266 | 25767 | Wiring Harness Leads from Three-pin Terminal (male half) to Two-pin Terminal (female half) and to Motor for 196222                                    |

| No.    | Plate | Name   |
|--------|-------|--|
| 196269 | 25783 | Lead (black) with Terminal and Insulating Sleeve for 196863  |
| 196270 | 25783 | Lead (red) with Terminal and Insulating Sleeve for 196863  |
| 196271 | 25767 | Wiring Harness Lead (from Three-pin Terminal to Light) for 196222 and 196778   |
| 196272 | 25767 | Two-pin Terminal (male half) complete (Controller Lead end) for 301-1 Machine, Nos. 51746X, 140589X, 196230, 196239, 196242, 196260 and two 140590 |
| 196282 | 25783 | Lead Sleeve for 196778   |
| 196291 | 25782 | Three-pin Terminal (female half) less Lead complete for 196224, Nos. 196228, 196229 and two each 1768X and 51093X                                  |
| 196319 | 25786 | Controller Plug Receptacle Lead Plug with Clamp and two 50764J, for 196683   |
| 196411 |       | Armature with Fan complete for PA2-1 Motor   |
| 196412 |       | Armature with Fan complete for PA2-3 Motor   |
| 196413 |       | Armature with Fan complete for PA2-5 Motor   |
| 196414 |       | Armature with Fan complete for PA2-6 Motor   |
| 196415 |       | Armature with Fan complete for PA2-7 Motor   |
| 196416 |       | Armature with Fan complete for PA2-9 Motor   |
| 196417 |       | Armature with Fan complete for PA2-10 Motor  |
| 196418 |       | Armature with Fan complete for PA2-11 Motor  |
| 196419 |       | Armature with Fan complete for PA2-12 Motor  |
| 196420 |       | Armature with Fan complete for PA2-14 Motor  |
| 196421 |       | Armature with Fan complete for PA2-15 Motor  |
| 196422 |       | Field Core with Coils and Terminals complete for PA2-1 Motor   |
| 196423 |       | Field Core with Coils and Terminals complete for PA2-3 Motor   |
| 196424 |       | Field Core with Coils and Terminals complete for PA2-5 Motor   |
| 196425 |       | Field Core with Coils and Terminals complete for PA2-6 Motor   |
| 196426 |       | Field Core with Coils and Terminals complete for PA2-7 Motor   |
| 196427 |       | Field Core with Coils and Terminals complete for PA2-9 Motor   |
| 196428 |       | Field Core with Coils and Terminals complete for PA2-10 Motor  |
| 196429 |       | Field Core with Coils and Terminals complete for PA2-11 Motor  |
| 196430 |       | Field Core with Coils and Terminals complete for PA2-12 Motor  |
| 196431 |       | Field Core with Coils and Terminals complete for PA2-14 Motor  |
| 196432 |       | Field Core with Coils and Terminals complete for PA2-15 Motor  |
| 196433 |       | Field Coil complete for PA2-1 Motor  |
| 196434 |       | Field Coil complete for PA2-3 Motor  |
| 196435 |       | Field Coil complete for PA2-5 Motor  |
| 196436 |       | Field Coil complete for PA2-6 Motor  |
| 196437 |       | Field Coil complete for PA2-7 Motor  |
| 196438 |       | Field Coil complete for PA2-9 Motor  |
| 196439 |       | Field Coil complete for PA2-10 Motor   |
| 196440 |       | Field Coil complete for PA2-11 Motor   |
| 196441 |       | Field Coil complete for PA2-12 Motor   |
| 196442 |       | Field Coil complete for PA2-14 Motor   |
| 196443 |       | Field Coil complete for PA2-15 Motor   |
| 196617 | 25780 | End Cover (commutator end) with Grease Tube  |
| 196630 | 25780 | Armature Shaft Bearing (pinion end)  |
| 196673 | 25786 | Junction Box for 196682  |
| 196674 | 25786 | Controller Plug Receptacle for 196682  |
| 196676 | 25786 | Junction Box Strain Relief (two piece) for 196682  |

| No.    | Plate | Name  |
|--------|-------|---|
| 196677 | 25786 | Controller Plug Receptacle Jumper Lead (brown) for 196682   |
| 196679 | 25786 | Junction Box Cover for 196682   |
| 196682 | 25784 | Junction Box complete for 196928, Nos. 196673, 196676, 196677, 196679, 196683, 196684, 197170, two 196674 and four 50637X   |
| 196683 |       | Controller Plug Receptacle Lead 197168 with 196319, for 196682  |
| 196684 | 25786 | Controller Plug Receptacle Jumper Lead (green) for 196682   |
| 196778 | 25783 | Wiring Harness with Three-Pin Terminal (male half) complete for 301-2 Machine, Nos. 196231, 196271 196282 and 196863  |
| 196861 | 25780 | Brush Spring  |
| 196862 | 25780 | Brush (carbon)  |
| 196863 |       | Wiring Harness less Three-pin Terminal (male half) from Three-pin Terminal to Motor, Nos. 196269 and 196270, for 196778   |
| 196892 | 25784 | Wiring Harness with Safety Switch (mercury) complete for 196929   |
| 196897 | 25784 | Controller with Six-pin Socket and Line Lead complete for 95 to 145 volts A.C. or D.C. Motor, for 196928, Nos. 194426, 196914, 196975 and two each 50791J and 140102X                   |
| 196901 | 25784 | Safety Switch (Mercury) Mounting Bracket for 196912   |
| 196907 | 25784 | Controller Lead with Six-pin Plug and Line Lead Retainer for 196929   |
| 196912 |       | Electrical Outfit with Safety Switch complete for School Tables Nos. 410, 414, 415 and 416, for 301-3 Machine, Nos. 196901, 196928 and two each 196929 and 197017                       |
| 196914 | 25785 | Controller Base 196931 with 23258, 192140, 193384, 193908, 194422, 194479, 194774, 194775, 196931, and two each 50587J, 51327J, 140100X, 140103X, 194421, 194514 and 931090, for 196897 |
| 196917 |       | Controller Base 196930 with 196939 and two each 23258, 140103X and 931090, for 194583 and 194827  |
| 196918 | 25781 | Controller Base 196930 with 196940 and two each 23258, 140103X and 931090, for 194584 and 194828  |
| 196919 |       | Controller Base 196930 with 196941 and two each 23258, 140103X and 931090, for 194585 and 194829  |
| 196928 |       | Wiring Outfit complete for School Tables Nos. 410, 414, 415 and 416, Nos. 196682, two 196897 and four wood screws 3/4 in. No. 8 R.H.B., for 196912                                      |
| 196929 |       | Wiring Outfit complete for 196912, Nos. 196892 and 196907   |
| 196930 | 25781 | Controller Base for 196917, 196918 and 196919   |
| 196931 | 25785 | Controller Base for 196914  |
| 196935 | 25781 | Controller Resistance Unit Linkage for 196939, 196940 and 196941  |
| 196937 | 25781 | Controller Resistance Unit Linkage Cross Slide for 196939, 196940 and 196941  |
| 196939 |       | Controller Resistance Unit with Linkage, Nos. 1783X, 196935, 196937, 196953 and two each 50587J, 51327J and 193384, for 32 to 55 volts, A.C. or D.C., for 196917                        |
| 196940 |       | Controller Resistance Unit with Linkage, Nos. 1783X, 196935, 196937, 196954 and two each 50587J, 51327J and 193384, for 95 to 145 volts, A.C. or D.C., for 196918                       |
| 196941 |       | Controller Resistance Unit with Linkage, Nos. 1783X, 196935, 196937, 196955 and two each 50587J, 51327J and 193384, for 150 to 250 volts, A.C. or D.C., for 196919                      |

NUMERICAL LIST OF PARTS

25766-1/2

| No.     | Plate | Name   |
|---------|-------|--|
| 196942  | ..... | Controller Starting Pitman for 301-3 Machine   |
| 196953  | ..... | Controller Resistance Unit, for 32 to 55 volts A.C. or D.C., for 196939                  |
| 196954  | 25781 | Controller Resistance Unit, for 95 to 145 volts A.C. or D.C. for 196940                  |
| 196955  | ..... | Controller Resistance Unit, for 150 to 250 volts, A.C. or D.C., for 196941               |
| 196975  | 25785 | Controller Lead with Six-pin Plug and Line Lead for 196897                               |
| 197017  | ..... | Safety Switch (Mercury) Mounting Bracket Gasket for 196912                               |
| 197168  | 25786 | Controller Plug Receptacle Lead (less plug) for 196683                                   |
| 197170  | 25785 | Controller Lead Receptacle Jumper Lead (black) for 196682                                |
| 200145C | 25776 | Rotating Hook Loop Guard Screw for 170158  |
| 200592C | 25776 | Rotating Hook Bobbin Case Tension Spring Screw for 45751                                 |
| 200614C | 25776 | Rotating Hook Gib Hinge Screw for 170158 and 170167                                      |
| 200964E | 25776 | Rotating Hook Bobbin Case Latch Stop Screw for 45751                                     |
| 201016F | 25776 | Rotating Hook Bobbin Case Tension Spring Regulating Screw for 45751                      |
| 206731  | 25776 | Rotating Hook Bobbin Case Latch Fulcrum Pin for 206736                                   |
| 206735  | 25776 | Rotating Hook Bobbin Case Latch for 206736   |
| 206736  | 25776 | Rotating Hook Bobbin Case Latch 206735 with 206731 and 206737, for 45751                 |
| 206737  | 25776 | Rotating Hook Bobbin Case Latch Lever for 206736   |
| 210736  | 25776 | Rotating Hook Bobbin Case Latch Spring for 45751   |
| 829736  | 25780 | Armature Shaft Bearing (pinion end) Retainer   |
| 931090  | ..... | Controller Resistance Unit Screw Washer (asbestos) for 196914, 196917, 196918 and 196919 |
| 931728  | 25766 | Light Switch Key Spring Washer for 196238  |
| 964270  | 25766 | Light Lead Grommet   |
| 964270  | 25779 | Machine Cradle Grommet for 170112  |
| 964514  | 25780 | Field Coil Wedge   |

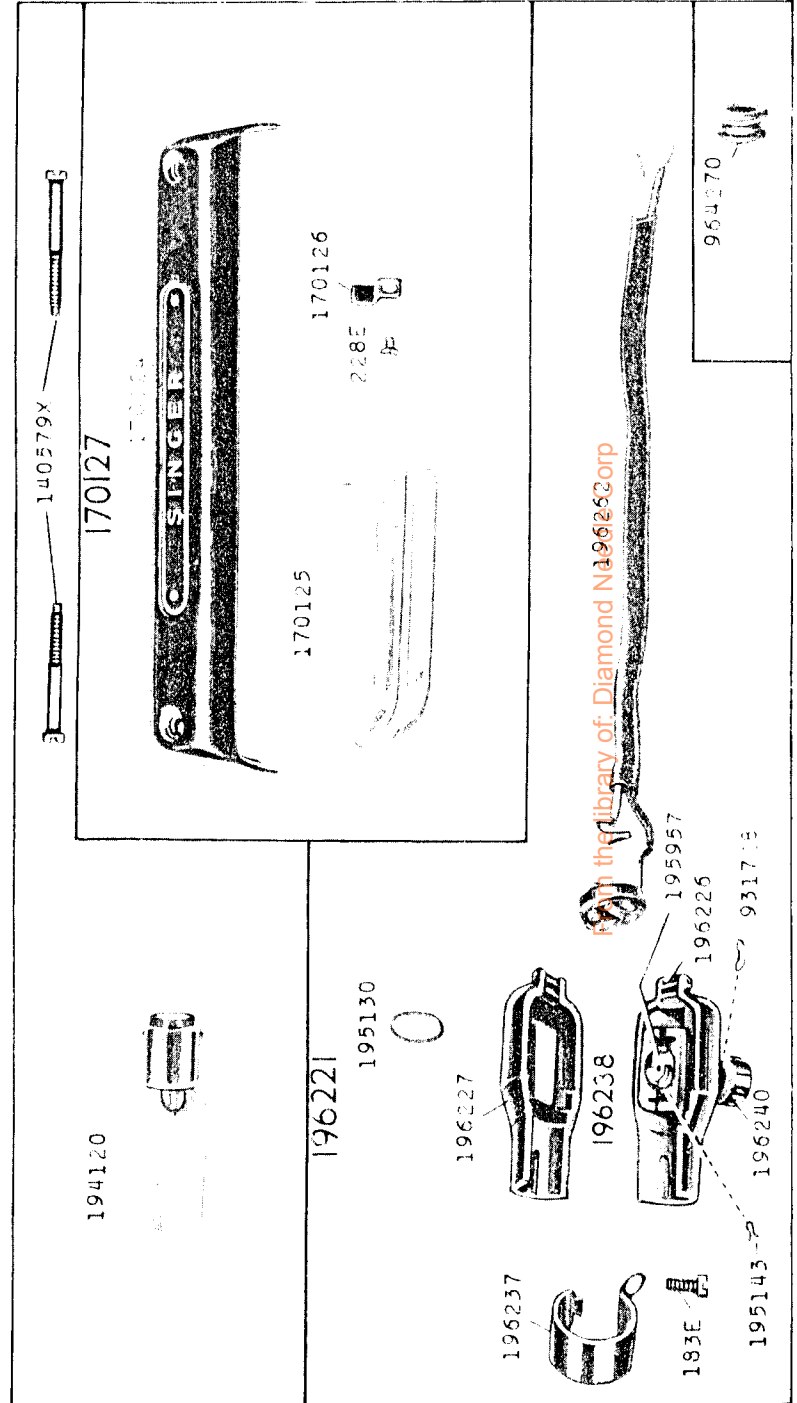

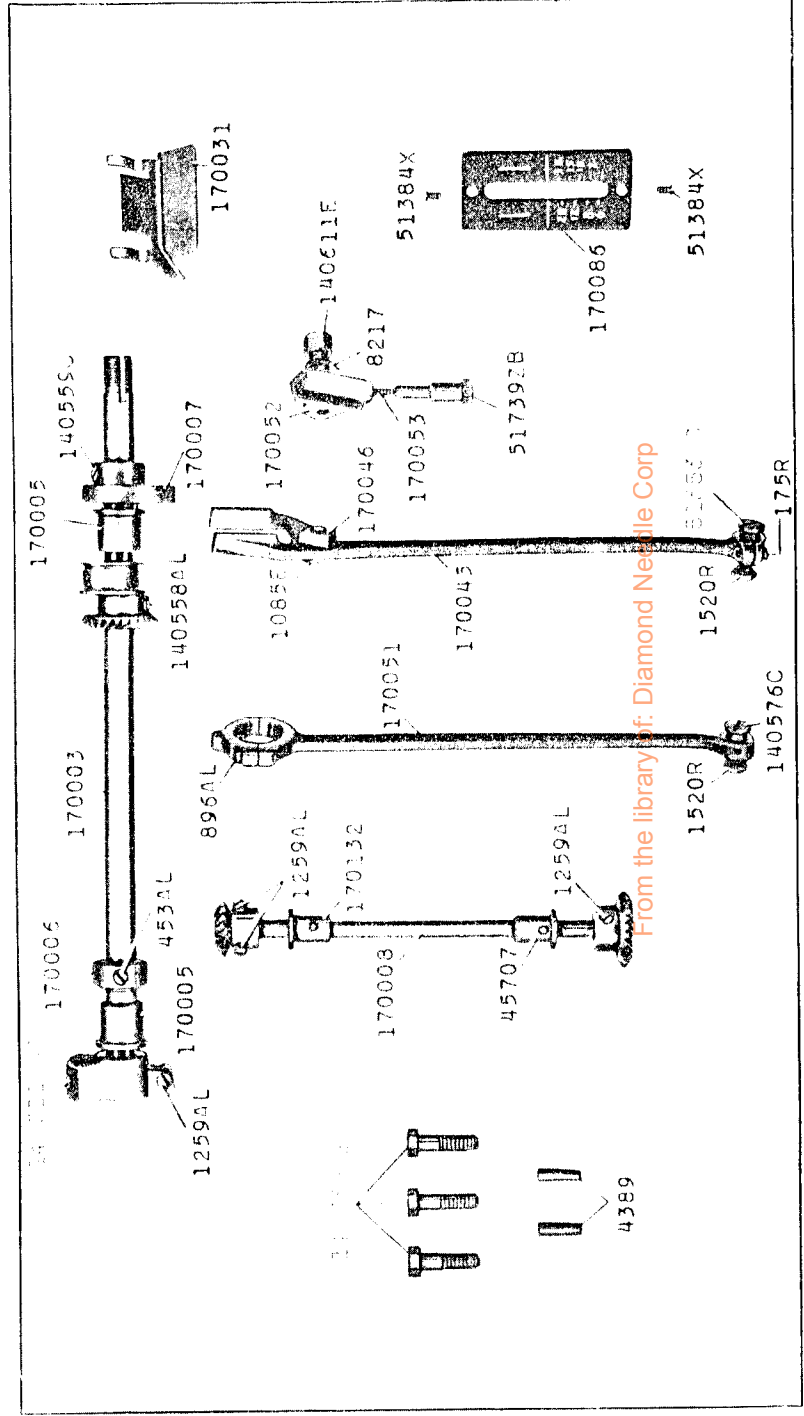
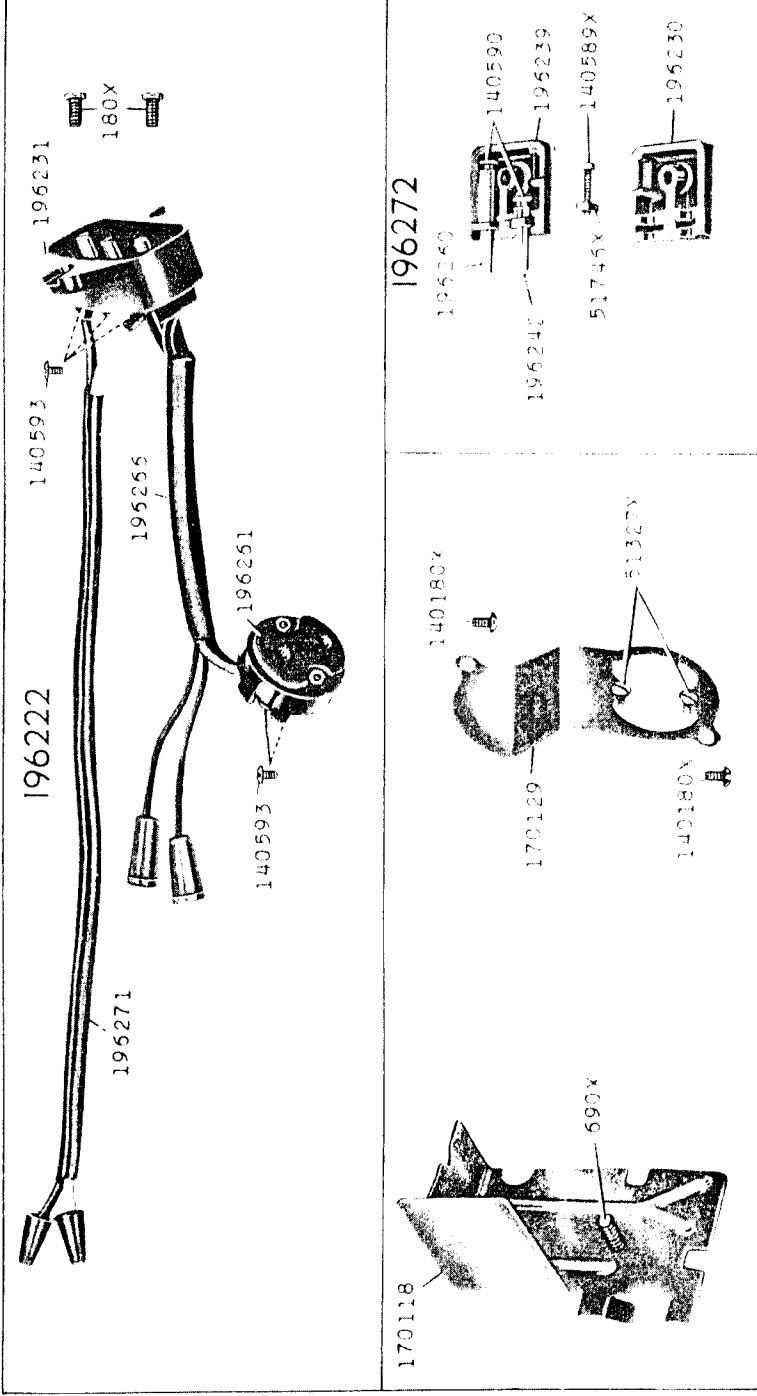

25769-1/3

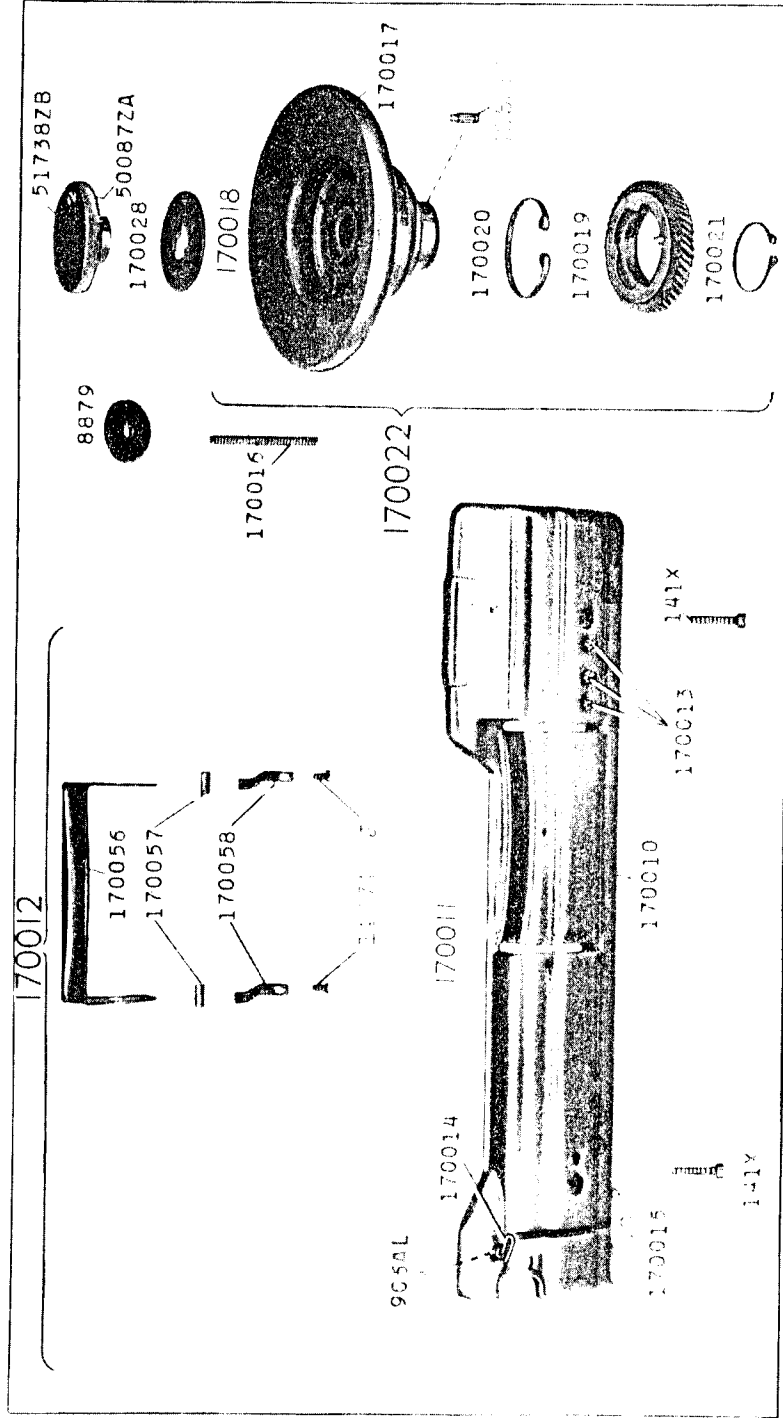

25770-1/3

301 1, 301-3

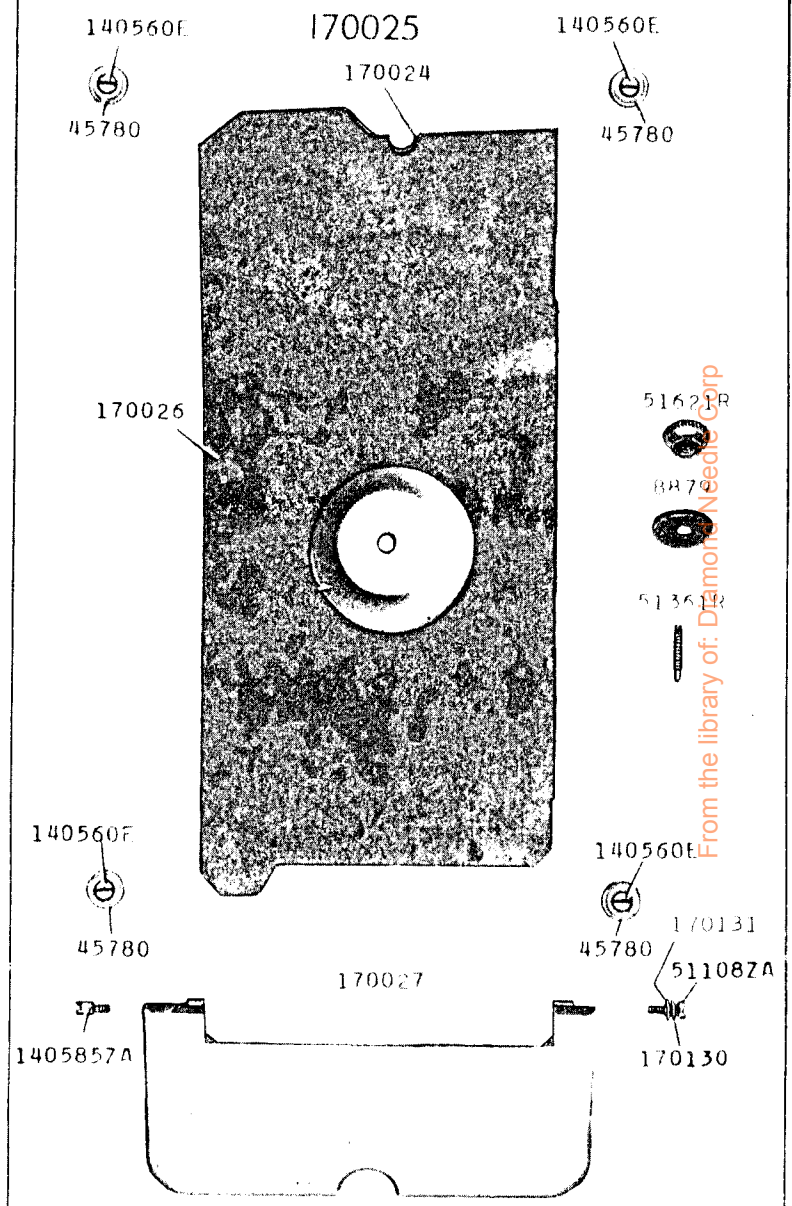

From the library of: Diamond Needs Corp

25771-1/3

301-2

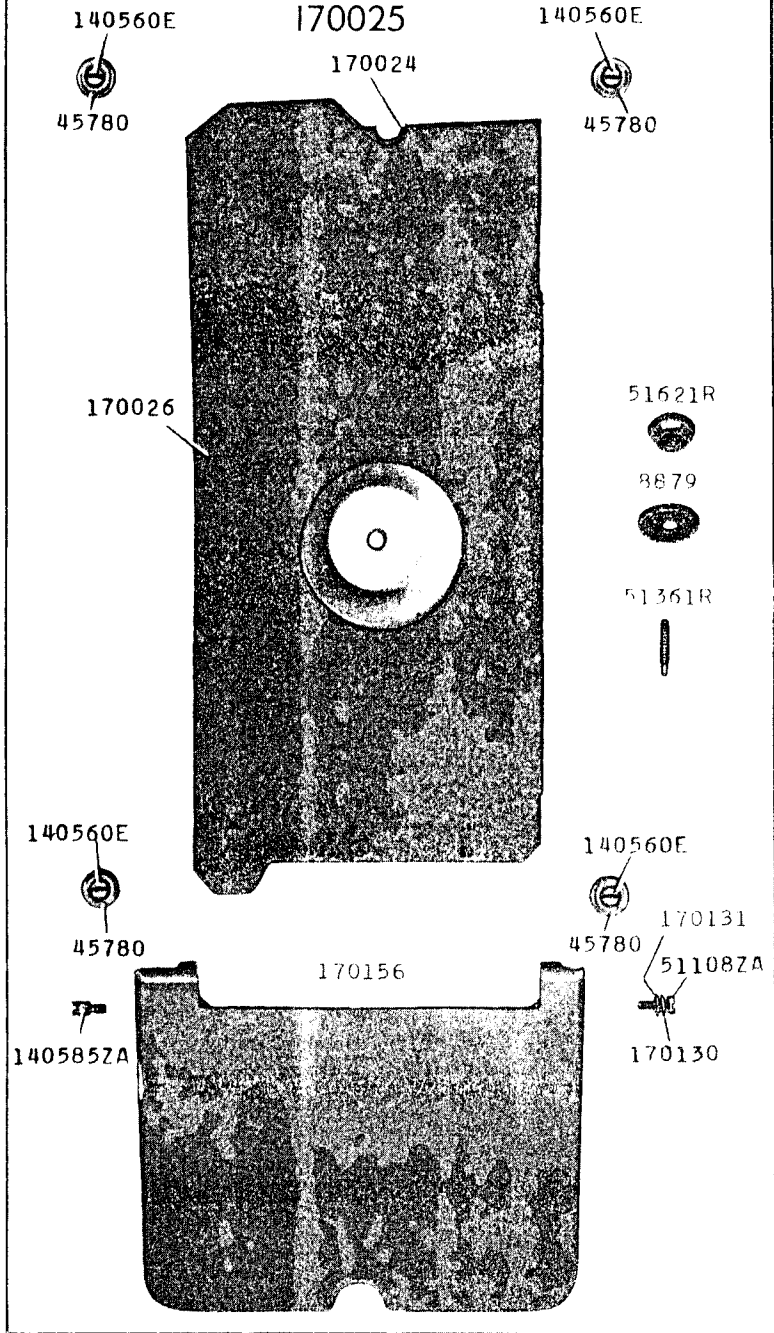

25772-1/2

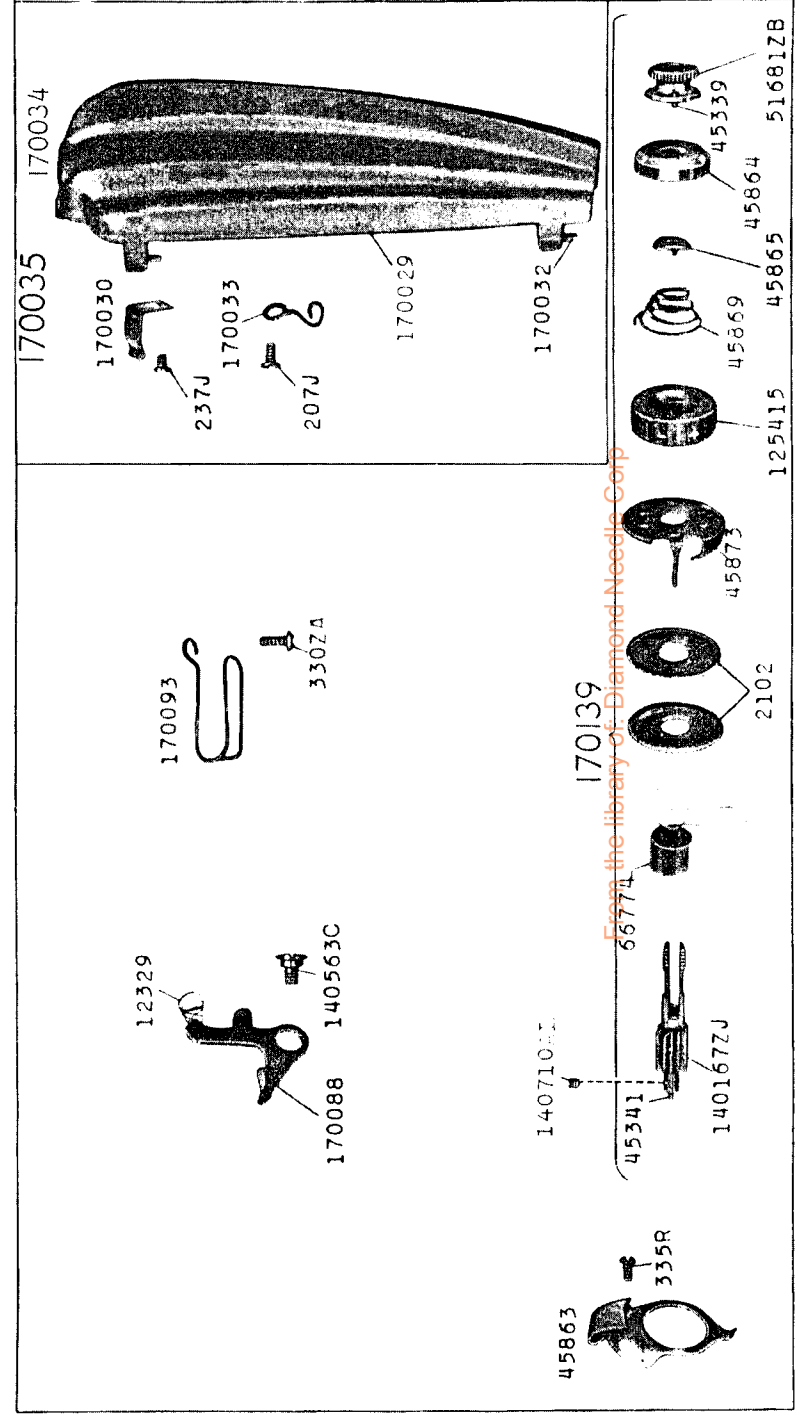

From the library of Diamond Needle Corp

25773-1/2

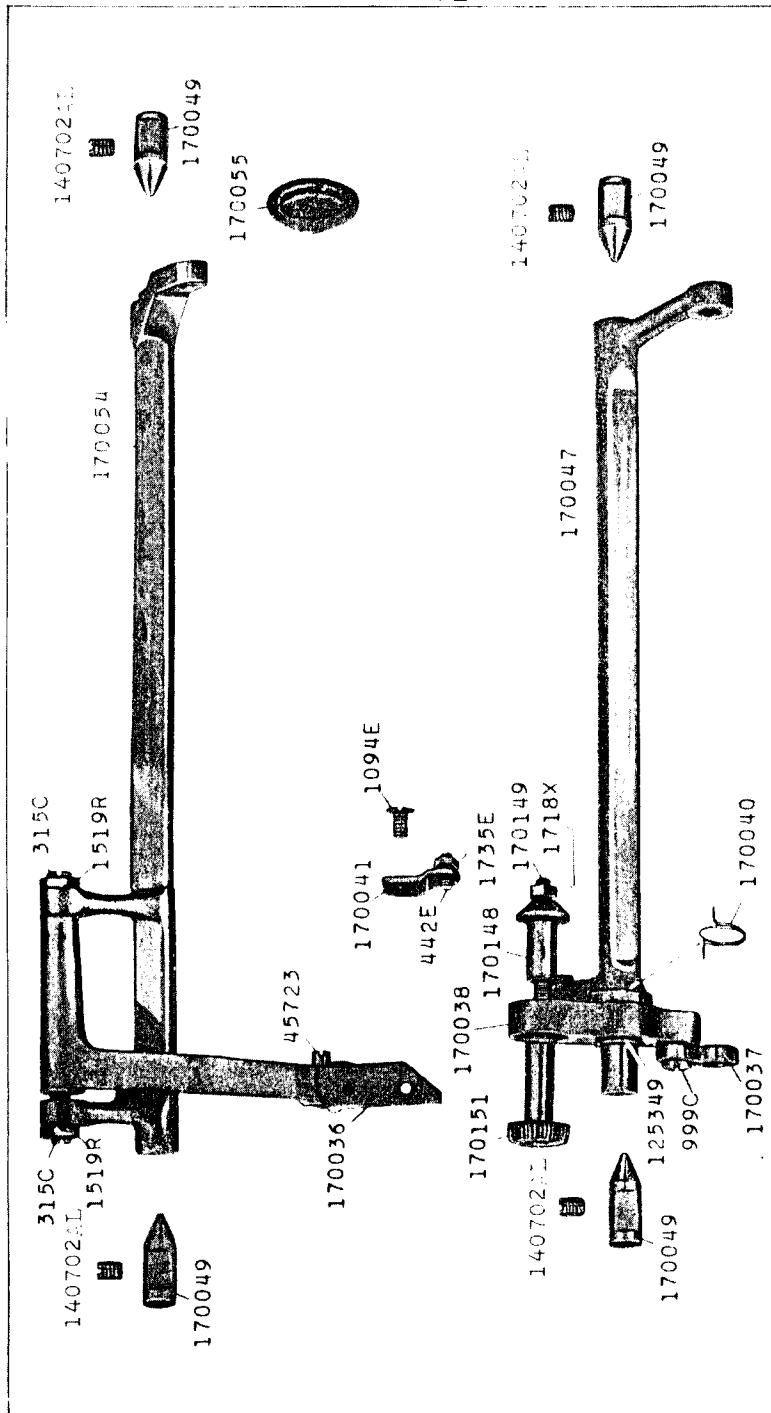

25774-2/3

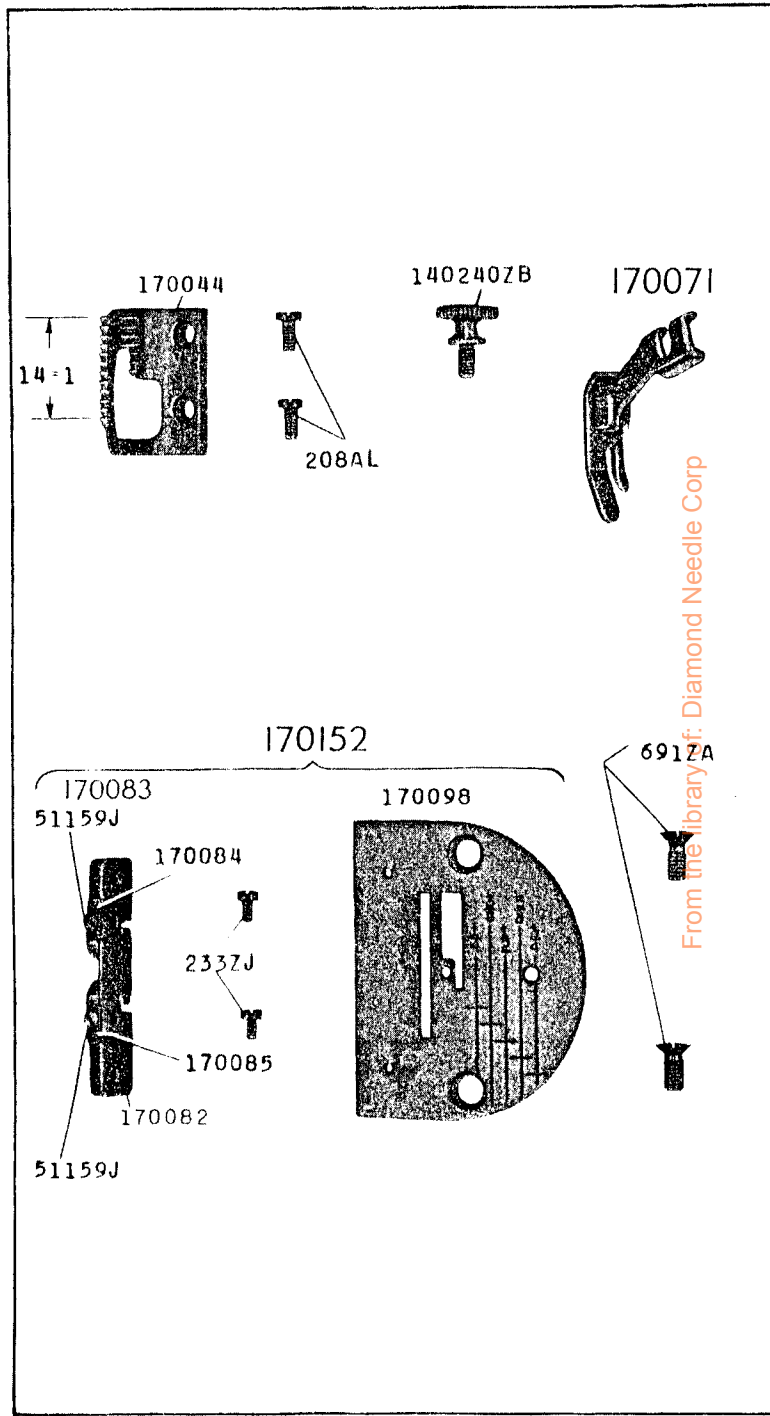

From the library of: Diamond Needle Corp

25775-1/2

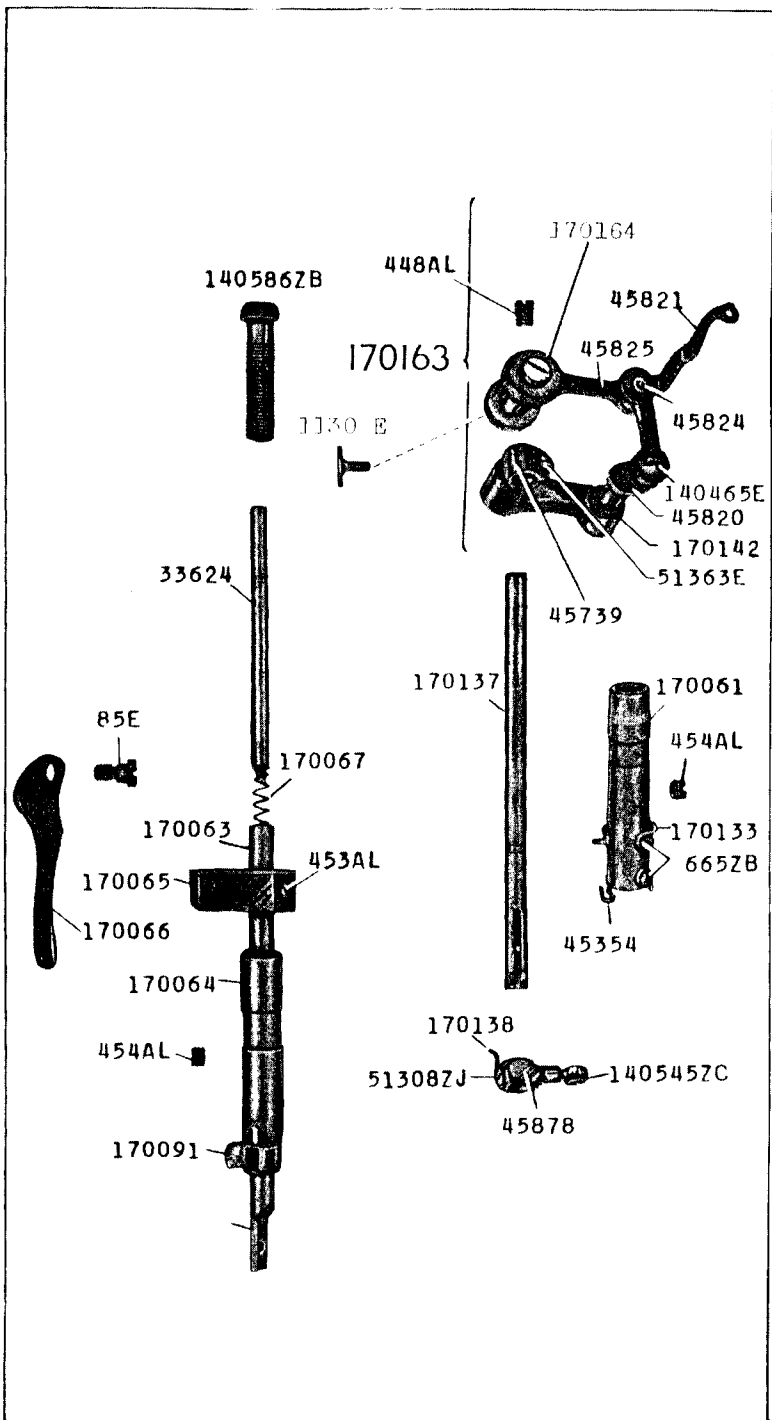

25776-2/3

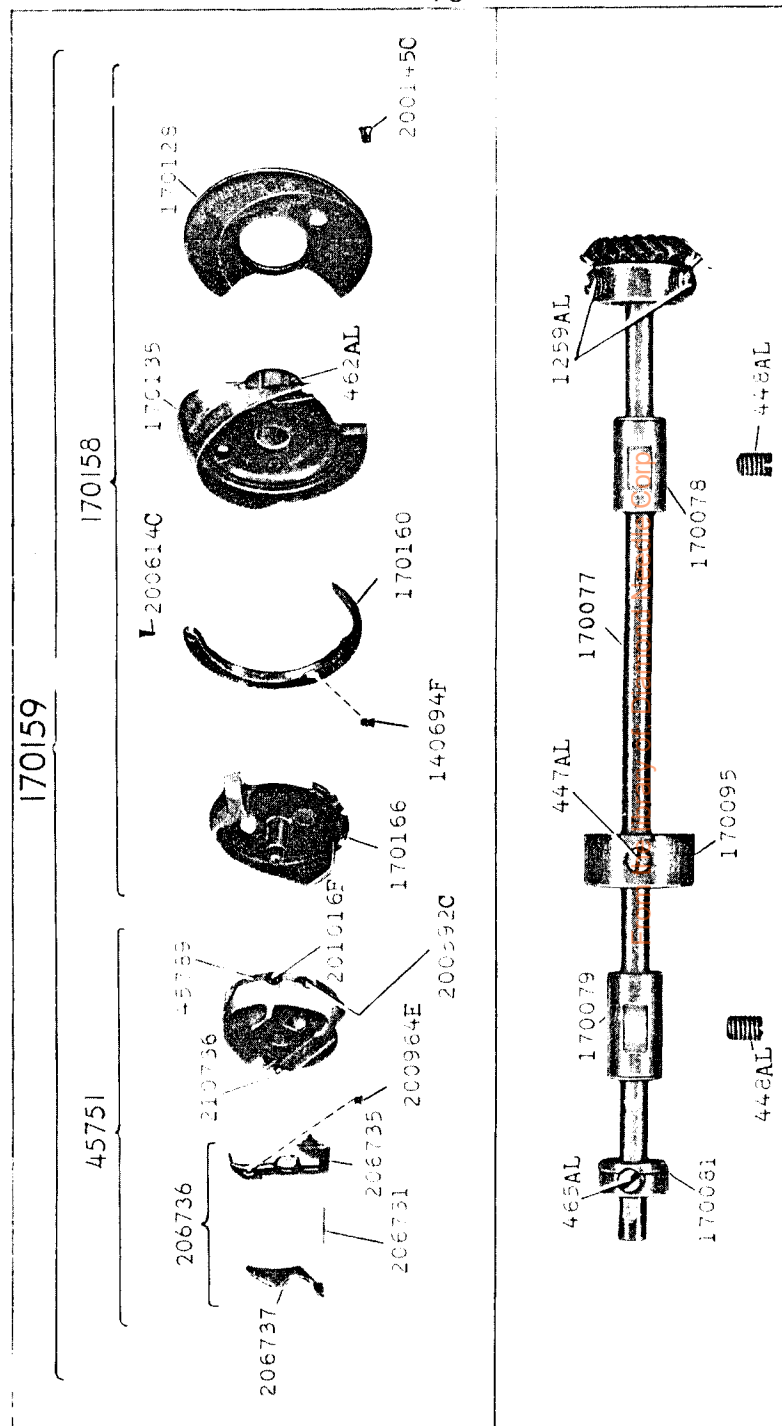



25777-1/2

160623

160629

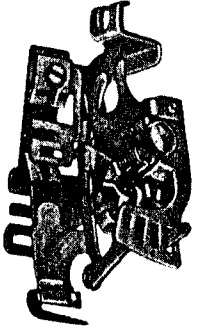

160624

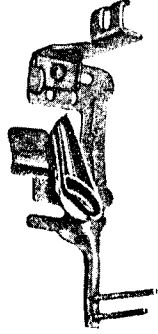

160625



160626

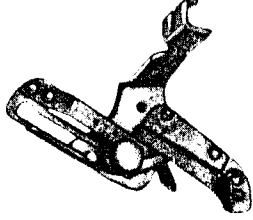

160628



160627



120378



25537

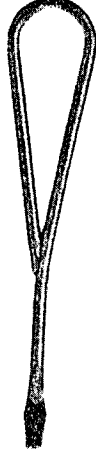

8879



45785



25778-2/3

170161



45915



45847



45916



140138



170162

20577



170016

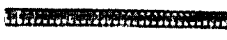

8879



15287



170109



50117E



170100

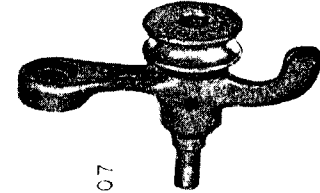

50464Z



170101



170107



From the literature: Diamond Needle Corp

170112

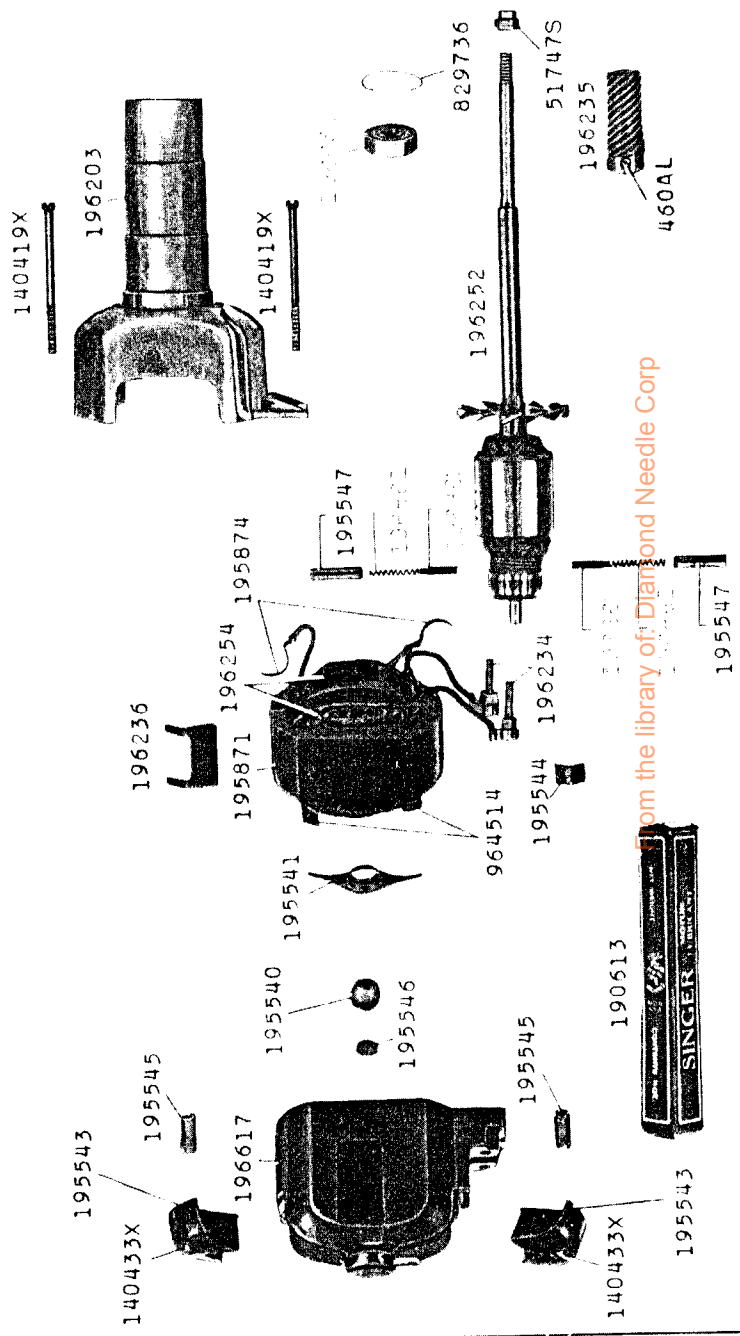
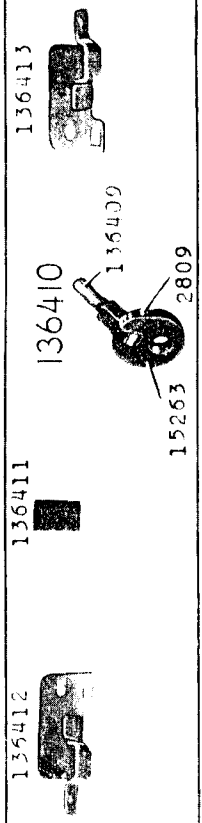
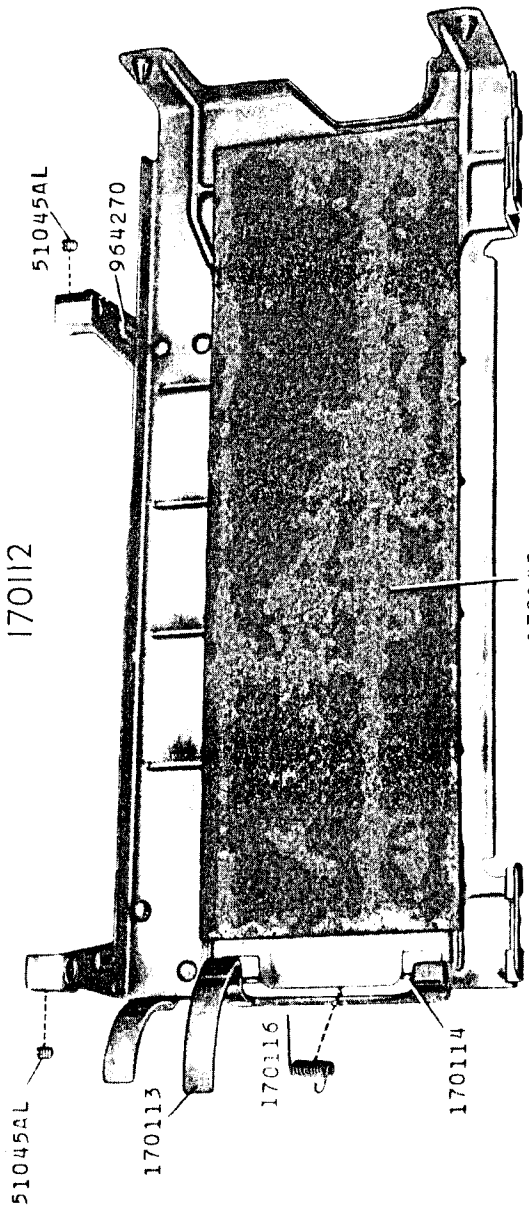

from the library of Diamond Needle Corp

25781-1/3

194828

194825

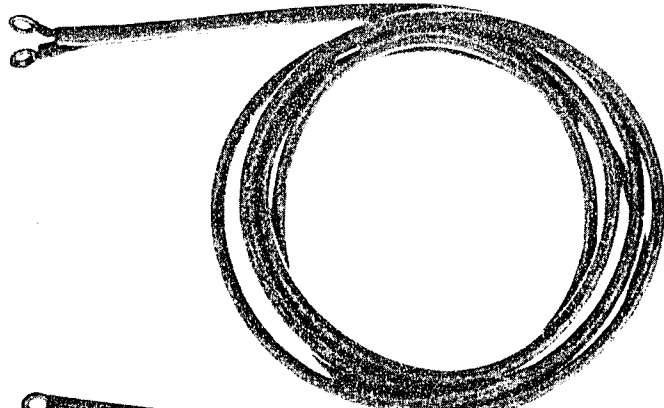

196918

196937

51327

1783

140103

196930

23258

140099

196936

193384

194954

194407

505871

194321

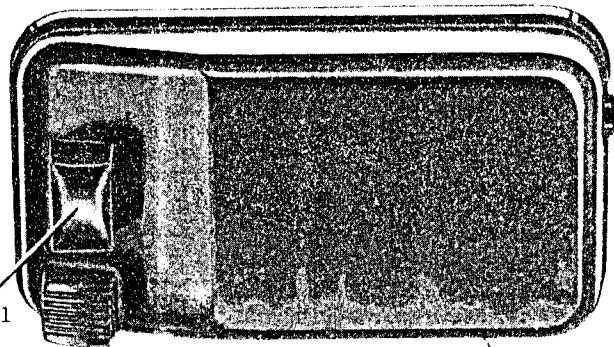

194573

301-I

25782-2/3

301-I

196291

1769 X

51398 X

196029

1785 X

51343 X

196023

196224

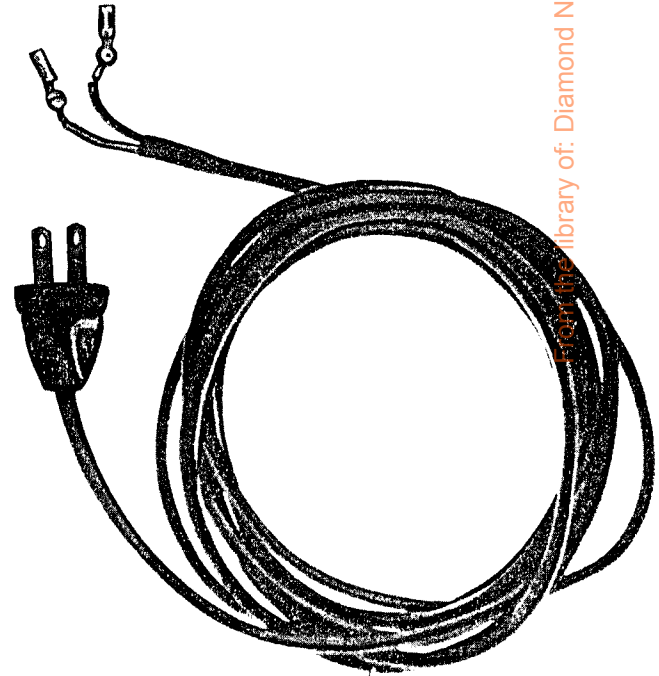

196217

From the library of: Diamond Needle Corp

25783-1/3

301-2

196778

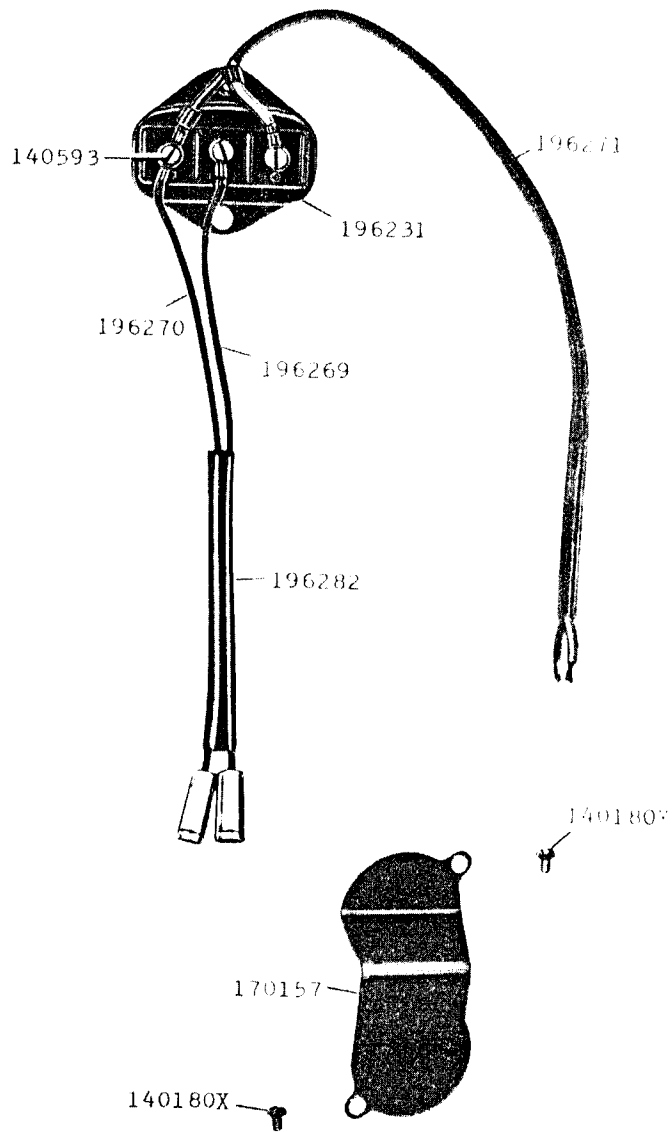

25784-1/3

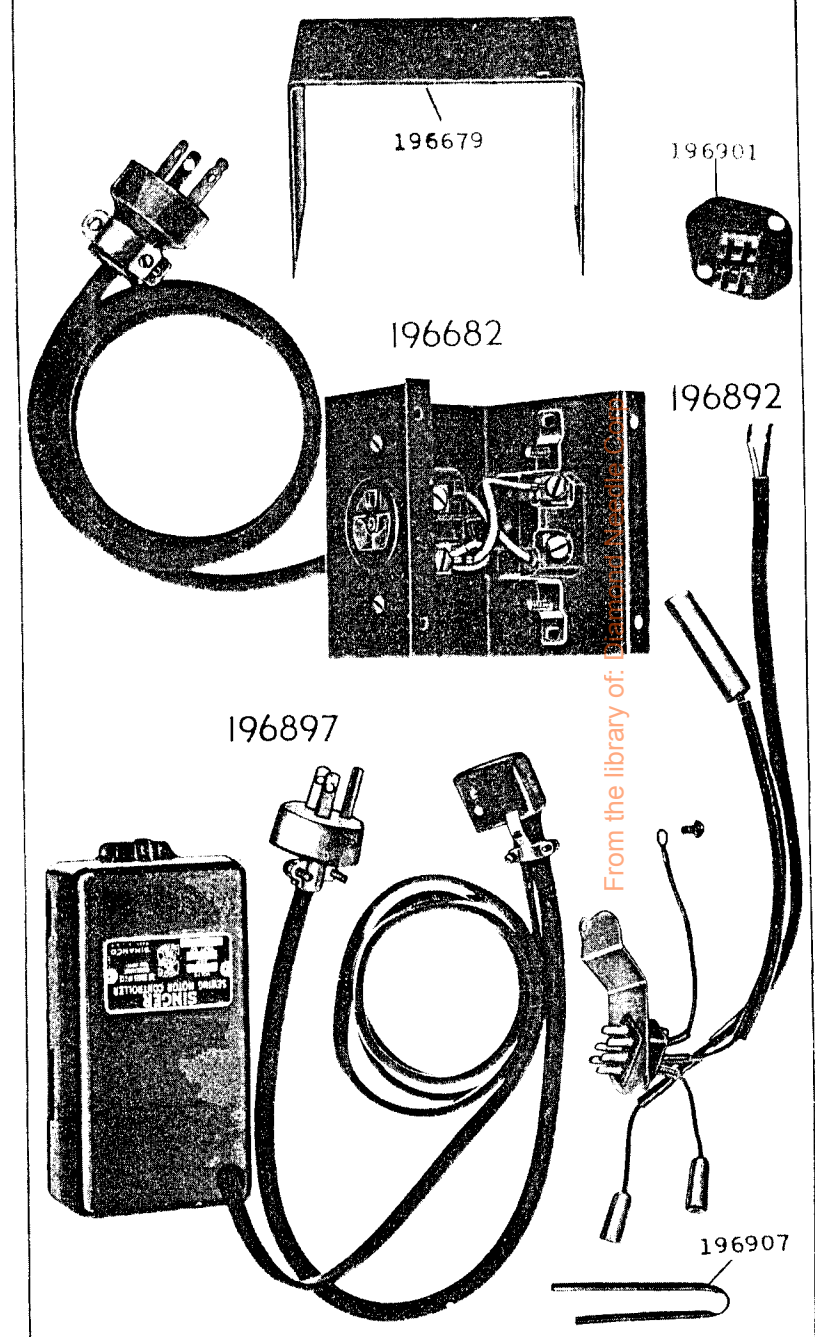

25785-2/3

196897

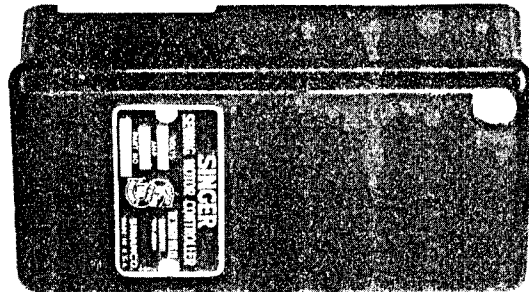
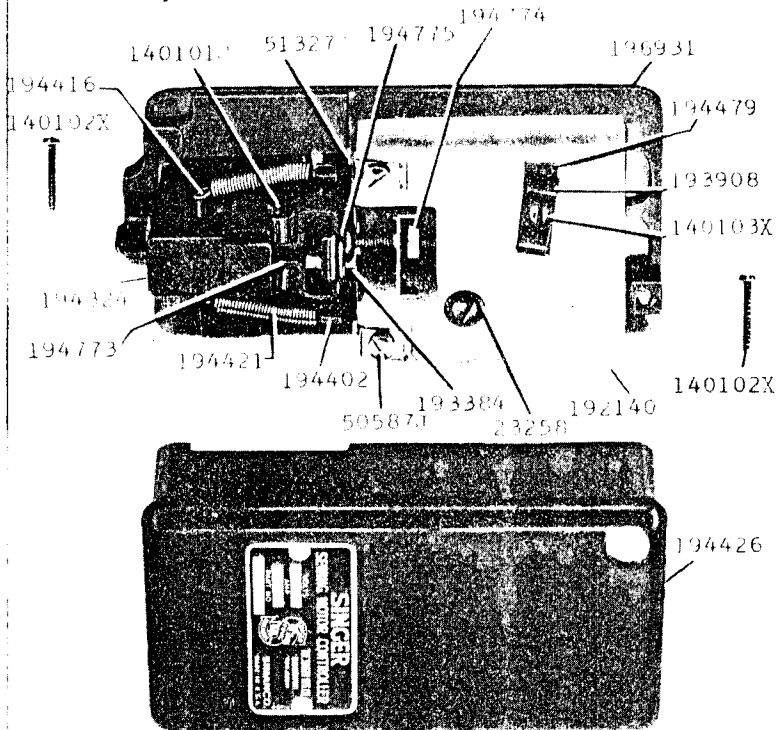
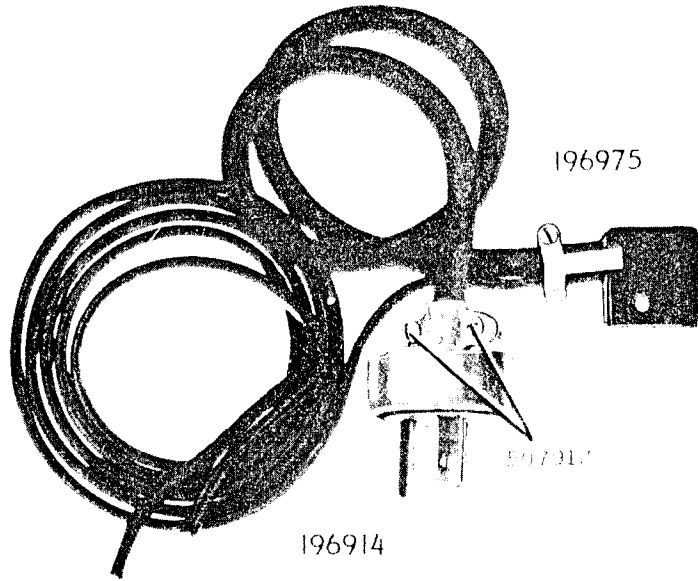

301-3

25786-1/3

196682

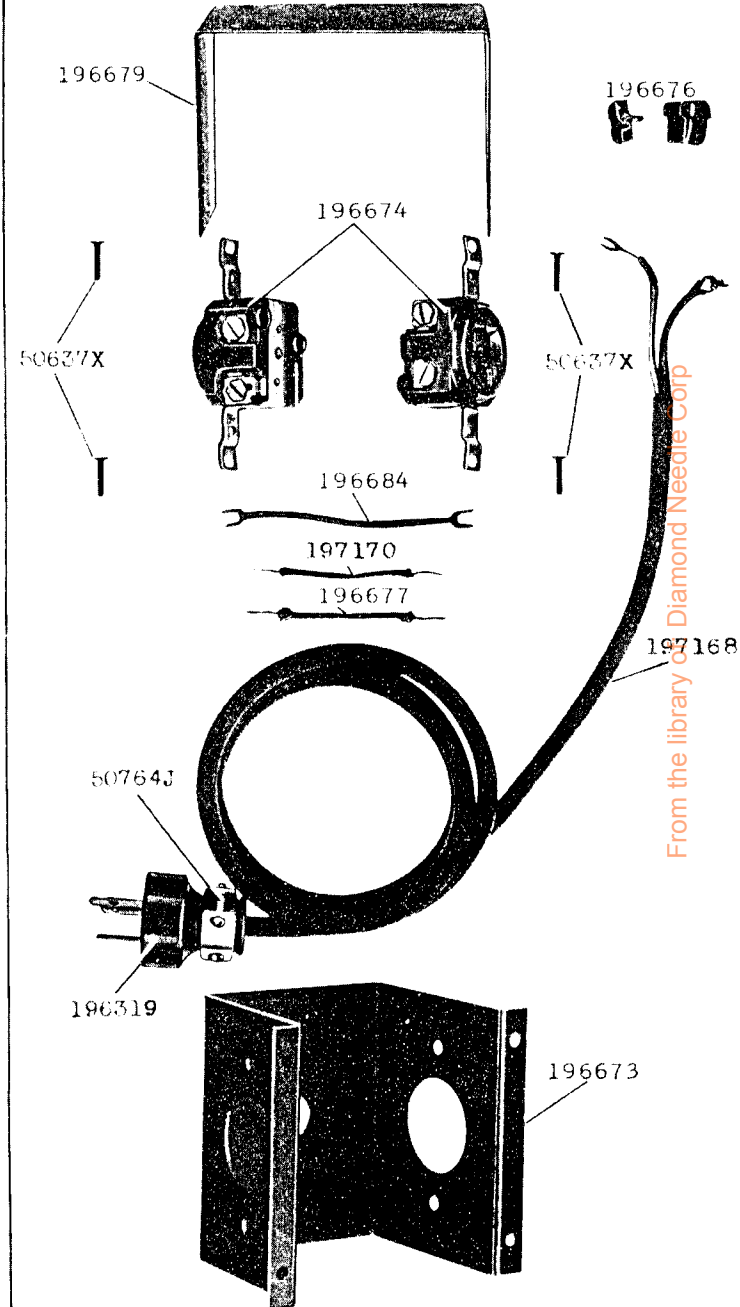

From the library of Diamond Needle Corp

25787-1/3

30!-2  
194584

195574

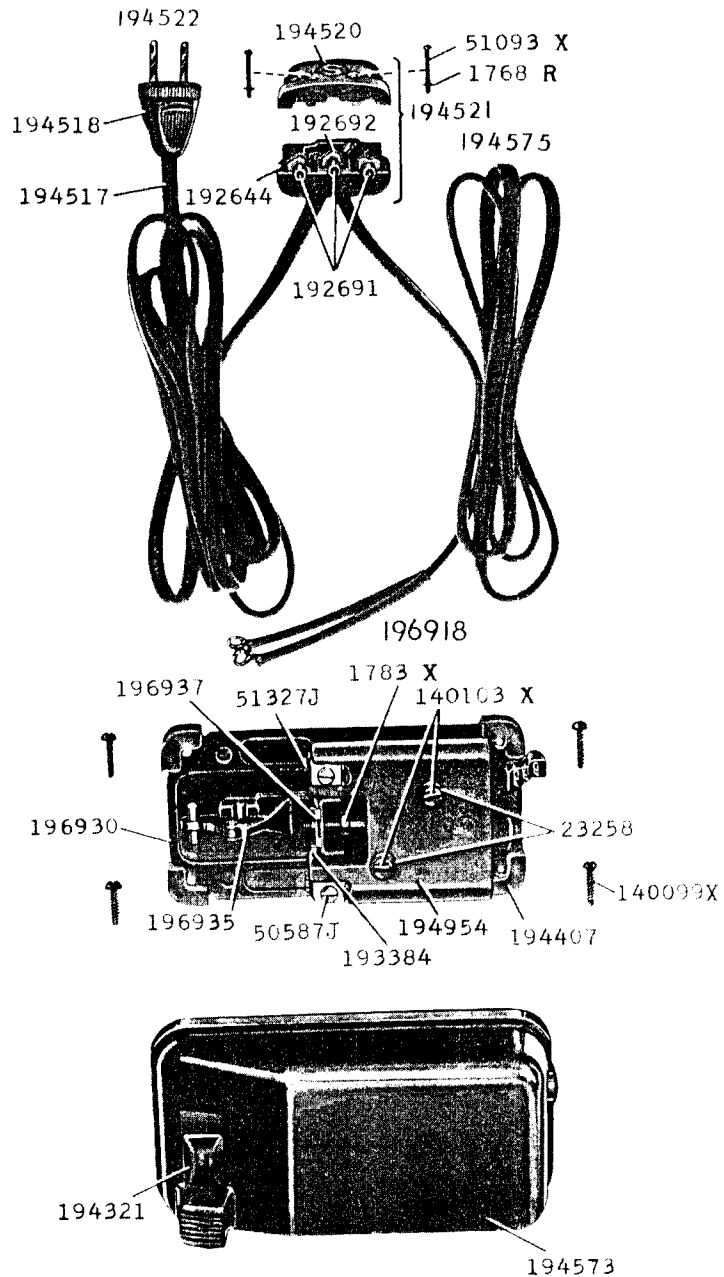

25788-1/2

160688

160687

160689

120861

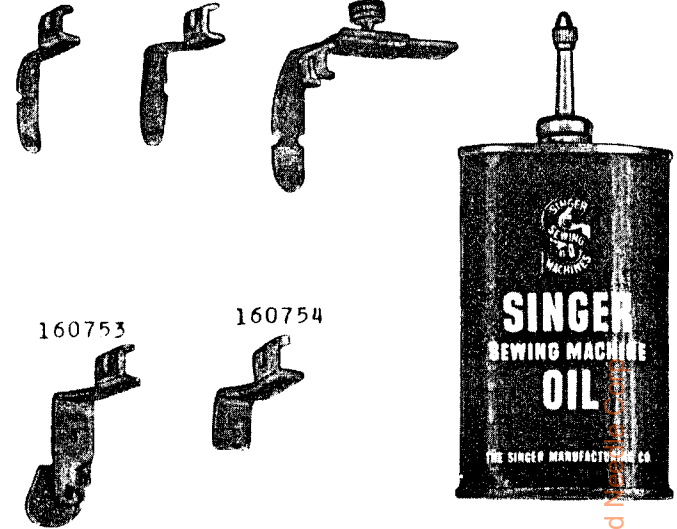

160690

160691

121632

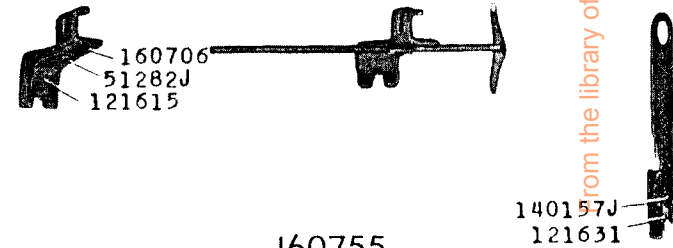

160755

35206

36696

3378

160763

35002

160762

35004

35003

35006

35005

from the library of: Diamond